

ENVIRONMENTAL HEALTH & SAFETY

UNIVERSITY *of* WASHINGTON

# UNIVERSITY OF WASHINGTON FALL PROTECTION PROGRAM MANUAL

---

December 2022



## TABLE OF CONTENTS

---

|   |    |
|---|----|
| Additional help .....   | 4  |
| PURPOSE .....   | 5  |
| SCOPE .....   | 6  |
| ROLES AND RESPONSIBILITIES .....                                    | 8  |
| FALL HAZARD ASSESSMENT .....  | 10 |
| Hierarchy of fall protection controls .....                         | 10 |
| Types of fall hazards and trigger heights for fall protection ..... | 12 |
| FALL PROTECTION REQUIREMENTS .....                                  | 14 |
| Roles and responsibilities .....                                    | 16 |
| 1. Hazard elimination .....   | 17 |
| 2. Passive systems .....  | 17 |
| 3. Fall restraint and positioning device systems .....              | 19 |
| 4. Fall arrest protection systems .....                             | 20 |
| 5. Administrative controls .....                                    | 21 |
| PROTECTION FROM FALLING OBJECTS .....                               | 22 |
| FALL PROTECTION WORK PLAN .....                                     | 24 |
| FALL PROTECTION EQUIPMENT .....                                     | 26 |
| ANCHORS .....   | 27 |
| Anchor types .....  | 27 |
| Anchor strength requirements .....                                  | 27 |
| Certifications and inspections of anchors .....                     | 30 |
| Labeling and records .....  | 30 |
| WALKING-WORKING SURFACES .....                                      | 31 |
| Stairs and stairways .....  | 32 |
| LADDERS .....   | 33 |
| Roles and responsibilities .....                                    | 35 |
| Portable ladder selection .....                                     | 35 |
| Ladder inspection .....   | 37 |
| Ladder use .....  | 37 |

|   |    |
|---|----|
| Fall protection on a portable ladder.....                               | 38 |
| Fixed ladders .....   | 39 |
| Ladder training.....  | 42 |
| SCAFFOLDS.....  | 43 |
| Roles and responsibilities .....  | 43 |
| MOBILE ELEVATING WORK PLATFORMS (MEWPs).....                            | 46 |
| Roles and responsibilities .....  | 46 |
| Scissor and personnel lifts .....                                       | 47 |
| Aerial lifts.....   | 47 |
| Procedures for MEWP use.....  | 47 |
| ROOF ACTIVITIES.....  | 49 |
| Roof access by contractors .....  | 49 |
| Work on a low slope roof (4:12 or less).....                            | 49 |
| Work on a steep slope roof (greater than 4:12) .....                    | 50 |
| Skylights, roof hatches and roof openings .....                         | 51 |
| Mechanical and other equipment maintenance.....                         | 52 |
| SPECIFIC WORK ACTIVITIES .....  | 53 |
| High voltage electrical work .....                                      | 53 |
| Tree work.....  | 53 |
| Excavations.....  | 53 |
| Theater and performing arts .....                                       | 53 |
| WINDOW CLEANING AND SUSPENDED MAINTENANCE OPERATIONS.....               | 55 |
| Roles and responsibilities .....  | 55 |
| Equipment for window cleaning and suspended maintenance operations..... | 56 |
| Safe use of rope descent systems.....                                   | 56 |
| Work platform systems .....   | 57 |
| Inspections and certifications.....                                     | 59 |
| TRAINING.....   | 60 |
| EMERGENCY FALL RESCUE AND ACCIDENT REPORTING.....                       | 62 |
| Emergency rescue.....   | 62 |
| Accident reporting .....  | 63 |

|  |     |
|--|-----|
| AUDITS, INSPECTIONS AND CERTIFICATIONS .....                         | 64  |
| Inspect prior to use.....  | 64  |
| Inspect every year .....   | 64  |
| Fall Protection Program inspections, certifications and audits ..... | 64  |
| RECORDKEEPING .....  | 66  |
| Record retention requirements.....                                   | 66  |
| CONTRACTORS .....  | 67  |
| REFERENCES.....  | 68  |
| APPENDICES.....  | 69  |
| Appendix A. Definitions.....   | 69  |
| Appendix B. Fall Protection Work Plan.....                           | 75  |
| Appendix C. Inspection checklist templates .....                     | 2   |
| Appendix D. Handrails and stair rail systems.....                    | 94  |
| Appendix E. Roof Access Permit .....                                 | 100 |
| Appendix F. Personal fall protection equipment .....                 | 103 |
| Appendix G. Inspecting fall protection equipment guides.....         | 106 |
| Log of revisions to Fall Protection Program Manual.....              | 109 |

## Additional help

This document provides a table of contents with hyperlinks to each section to assist the reader in accessing specific information more quickly. The document provides information to fulfill the minimum applicable regulatory requirements and does not cover every conceivable hazard.

If you need additional assistance in identifying fall protection controls, or in selecting personal fall protection equipment for a fall hazard, contact the Environmental Health & Safety (EH&S) Occupational Safety and Health office at 206.543.7262.

## PURPOSE

---

Falls are among the most common causes of serious work-related injuries and deaths. The University of Washington (UW), through the UW Fall Protection Program, is committed to protecting employees and others from fall hazards through safe design, hazard elimination, engineering controls, safe work practices, training, and personal protective equipment when necessary. If a fall hazard cannot be eliminated, effective fall protection must be planned, implemented, and monitored to control the risks of injury due to falling.

According to Washington State Department of Labor and Industries regulations, regardless of the fall distance, in Washington state **ALL** employers have a duty of care to protect employees from being exposed to serious injury or death while working at heights, including above or adjacent to dangerous equipment or machinery. The requirements in this document must be in accordance with all applicable regulations, codes, standards, and industry best practices.

[Back to Top](#)

## SCOPE

The UW Fall Protection Program Manual applies to all departments on UW campuses, off-campus UW work locations and leased properties where any type of activity, indoors or outdoors, could result in injuries from falls. All employees and personnel engaged in work-related activities where there is a risk of falling from an elevation are required to follow the requirements outlined in this document. Specifically, this document covers identification and assessment of fall hazards, prevention measures, and safe work practices to reduce the risk of falling when working at heights.

For all UW work locations, the Washington State Department of Labor and Industries regulates fall protection under the Washington Administrative Code (WAC) [296-880](#) Unified Safety Standards for Fall Protection for all industries. Fall Protection is also covered under [WAC 296-24](#) for Walking-Working Surfaces and [WAC 296-876](#) for Ladders, Portable and Fixed. Some work tasks have additional requirements not addressed in WAC 296-880 as shown below with the specific regulation that applies.

| Work task  | WAC number          |
|--|---------------------|
| Construction work                                      | WAC 296-155         |
| Work on elevating work platforms                       | WAC 296-869         |
| Work on powered platforms                              | WAC 296-870         |
| Window cleaning  | WAC 296-878         |
| Work on scaffolds                                      | WAC 296-874         |
| Work on cranes   | WAC 296-155, Part L |
| Telecommunications work                                | WAC 296-32          |
| Work by qualified electrical workers                   | WAC 296-45          |
| Ship repairing, shipbuilding, shipbreaking             | WAC 296-304         |
| Longshore, stevedore and waterfront related operations | WAC 296-56          |

The Unified Safety Standards will apply to the majority of maintenance and service work performed by UW employees; however, the other standards listed above will apply to specific work tasks.

Construction work is defined as "...construction, alteration, repair, demolition..." and the construction standard applies to all employees doing this work, not only individuals working in construction industries. Renovations and repairs may be considered construction, but routine maintenance and small-scale tasks and repairs generally are not. Maintenance activities can be defined as maintaining a structure, fixture, or foundation in proper condition on a regular basis. When unsure, the safest course of action is to follow the most conservative regulations.

Excluded from this document are walking surfaces accessed by non-employee or the general public that are managed under different programs and regulatory requirements.

*Note: University units and departments can use this Fall Protection Program Manual to meet compliance requirements. Where unit or department specific processes and practices are required, additional details may be added as an addendum to this program manual as long as the requirements are equal to or more stringent and do not conflict with the information provided in this document.*

[Back to Top](#)

## ROLES AND RESPONSIBILITIES

| Role   | Responsibility  |
|--|---|
| <b>Department or unit management</b>                 | <ul style="list-style-type: none"> <li>• Provide the necessary resources to ensure the implementation and maintenance of the UW Fall Protection Program.</li> <li>• Identify areas at UW owned and leased facilities where there is a risk of serious injury due to falling.</li> <li>• Appoint Competent Person(s) to assess fall hazards, and develop, implement, and evaluate Fall Protection Work Plans.</li> <li>• Appoint Qualified Person(s) to design, engineer, and maintain fall protection systems as required.</li> <li>• Ensure employee(s) are trained to identify and control fall hazards.</li> <li>• Know and follow the UW Fall Protection Program Manual.</li> <li>• Approve alternative fall protection systems as needed.</li> <li>• Coordinate emergency fall rescue as needed.</li> </ul>  |
| <b>Environmental Health and Safety (EH&amp;S)</b>    | <ul style="list-style-type: none"> <li>• Maintain the UW Fall Protection Program Manual and update as needed.</li> <li>• Review new or revised Fall Protection Work Plans used by client groups as needed during the planning phase of a project requiring fall protection safeguards.</li> <li>• Provide guidance on appropriate fall protection equipment, tie-off points, and engineered systems.</li> <li>• Ensure the UW Fall Protection Program Manual is compliant with state and federal regulations, building codes, UW policies, standards, documented procedures, and industry best practices.</li> <li>• Conduct periodic and documented audits of the UW Fall Protection Program.</li> <li>• Work with UW Facilities to maintain and update the <a href="#">UW Facilities Design Standard</a>, for safe access and fall protection.</li> </ul> |
| <b>UW Facilities and Engineering (or equivalent)</b> | <ul style="list-style-type: none"> <li>• Design, engineer, and inspect fall protection systems.</li> <li>• Provide the necessary Qualified Persons to design, engineer, and maintain fall protection systems.</li> <li>• Maintain records on all fall protection installations, repairs, and trainings.</li> </ul>  |
| <b>Contractors</b>                                   | <ul style="list-style-type: none"> <li>• Provide the UW with their fall protection program documents for review prior to performing work.</li> <li>• Provide appropriate fall protection systems for company employees as required by law, including but not limited to, guardrail systems and personal fall protection systems.</li> <li>• Complete Job Hazard Analyses and Fall Protection Work Plans in accordance with regulatory requirements, standards, and industry best practices.</li> <li>• Complete UW Roof Access Permits as required.</li> </ul>  |



The roles and responsibilities of Qualified Persons, Competent Persons, Authorized Persons, and employees are different for specific work activities that require fall protection. The roles and responsibilities are described in each section of this document: Fall Protection Requirements, Scaffolds, Ladders, Mobile Elevating Work Platforms, and Window Cleaning and Suspended Maintenance Operations.

[Back to Top](#)

## FALL HAZARD ASSESSMENT

---

Identifying fall hazards involves recognizing any work process, activity, or situation with the potential to cause injury or harm to a person due to a risk of falling when working at heights. The hazards must always be identified, risks assessed, and the proper controls put into place prior to starting work. The process of fall hazard identification, assessment, and control should be repeated when changes to work activities are planned or occur without prior notice.

Assessing fall hazards for specific work activities can be done using the UW [Job Hazard Analysis \(JHA\) template](#) or an equivalent tool. A customized document can also be developed to conduct and document a thorough assessment of fall hazards, and determine the best controls for conducting the work.

### Hierarchy of fall protection controls

The five levels in the hierarchy of fall protection controls are defined and illustrated below. Hazard elimination is the first and best control to protect employees from fall hazards. UW Facilities architectural and facility design standards incorporate safe access and fall protection requirements for new construction and renovations, which can eliminate fall hazards. The last control method, administrative controls, is not recommended and considered a last resort when safer alternatives cannot be used.

[Back to Top](#)

1. **Hazard Elimination:** Evaluating the design to eliminate fall hazards or changing the task, process, controls, or other means to remove the need for any employee to be exposed to a fall hazard.
2. **Passive Fall Protection:** Fall protection that does not require the wearing or use of personal fall protection equipment. An example is a guardrail system.
3. **Fall Restraint:** The technique of securing an employee to an anchorage using a full body harness and lanyard short enough to prevent the person's center of gravity from reaching the fall hazard.
4. **Personal Fall Arrest System (PFAS):** A system comprised of, at a minimum, an anchorage, full body harness, lanyard, and connectors used to arrest an employee from free falling more than six feet in a fall from an elevated level.
5. **Administrative Controls:** Employer mandated safe work practices or procedures that prevent exposure to a fall by signaling or warning an employee to avoid approaching a fall hazard. Examples include warning lines and safety monitors.

**HIERARCHY OF FALL PROTECTION**

The Hierarchy of Fall Protection is the preferred order of control for fall hazards. As the Hierarchy progresses, so does the risk.

**1 HAZARD ELIMINATION**  
Preferred solution is to eliminate exposure to the fall hazard.

**2 PASSIVE FALL PROTECTION**  
Physical barriers, like guardrails around unprotected edges and covers over holes.

**3 FALL RESTRAINT SYSTEMS**  
Use personal protective equipment to restrict the worker's range of movement so they cannot fall.  
\*Training required

**4 FALL ARREST SYSTEMS**  
Use personal protective equipment to arrest a fall within acceptable force and clearance margins.  
\*Training and rescue planning required

**5 ADMINISTRATIVE CONTROLS**  
Least preferred solution is work practices or procedures that increase a worker's awareness of a fall hazard.  
\*Not recommended

PROTECTING WORKERS AT HEIGHT | ENGINEERING | TRAINING | EQUIPMENT | TESTING

800 755 8455 www.gravitec.com

Source: [Gravitec Systems, Inc.](https://www.gravitec.com)

## Types of fall hazards and trigger heights for fall protection

Examples of workplace conditions that could result in falls are listed in the table below with the trigger heights that indicate when fall protection is required by regulations or policy.

| Fall Protection Trigger Heights  |  |                                |
|--|--|--------------------------------|
| General fall protection  | Trigger height                                     | Regulation/Policy              |
| Above or adjacent to dangerous equipment, hazardous materials or conditions                              | Regardless of height                               | 296-880-10010(1)               |
| Holes into which an employee can trip, step into or step through   | Regardless of height                               | 296-880-10010(2)               |
| Impalement hazards – falling into or onto  | Regardless of height                               | 296-880-10010(3)               |
| When on a walking-working surface  | Four feet or more                                  | 296-880-20005                  |
| Unguarded sides and edges (floors, stairs, roofs, ramps, bridges, loading docks)                         | Four feet or more                                  | 296-880-20005(1)               |
| Ramps, runways, inclined walkways  | Four feet or more                                  | 296-880-20005(2)               |
| Holes – where work is being performed  | Four feet or more                                  | 296-880-20005(3)               |
| Skylights  | Four feet or more                                  | 296-880-20005(3)(b)            |
| Hatchways and chute holes  | Four feet or more                                  | 296-880-20005(3)(c)            |
| Ladderway or platform  | Four feet or more                                  | 296-880-20005(3)(d)            |
| Pits and trapdoor holes  | Four feet or more                                  | 296-880-20005(3)(e)            |
| Repair pits and service pits   | Four feet or more                                  | 296-880-20005(3)(f)            |
| Manholes   | Four feet or more                                  | 296-880-20005(3)(g)            |
| Openings – wall: at least 30 inches high X 18 inches wide  | Four feet or more                                  | 296-880-20005(4)               |
| Formwork and reinforcing work  | Four feet or more                                  | 296-880-20005(5)               |
| Roof – steep slope (greater than 4:12) unguarded edge, any work  | Four feet or more                                  | 296-880-20005(6)               |
| Roof – low slope (less than 4:12) unguarded edge, work other than roofing or constructing a leading edge | Four feet or more                                  | 296-880-20005(7)               |
| Hazardous slopes   | Four feet or more                                  | 296-880-20005(9)               |
| Vehicles and rolling stock – If suitable anchorages cannot be provided or creates a greater hazard       | Four feet or more                                  | 296-880-20005(10)              |
| <b>Specific requirements not addressed in WAC 296-880-200 (above)</b>                                    |  |                                |
| <b>Stairways</b> See also WAC 296-24   |  |                                |
| Stairs   | Four or more risers or greater than 30 inches high | 296-24-74015 and 296-880-40005 |
| Stairways – opening created by the stairway  | Four feet or more                                  | 296-880-20005(4)               |
| <b>Ladders</b> See also WAC 296-876  |  |                                |
| Ladder (fixed) – extend more than 24 feet above a lower level  | Greater than 24 feet                               | 296-876-60065                  |
| Ladder work (portable) both hands used for work task   | Greater than ten feet                              | UW policy                      |
| <b>Construction work</b> See also WAC 296-155  |  |                                |
| Roof - low slope (less than 4:12) unguarded edge, constructing a leading edge                            | Six feet or more                                   | 296-880-30005(1)               |
| Roof - low slope (less than 4:12) unguarded edge, roofing work   | Six feet or more                                   | 296-880-30005(1)               |
| Erection or placement of structural members  | Ten feet or more                                   | 296-880-30005(1)               |
| Excavation and trenching work  | Ten feet or more                                   | 296-880-30005(1)               |

| General fall protection   | Trigger height                                   | Regulation/Policy             |
|---|--|-------------------------------|
| <b>Mobile Elevating work platforms (MEWP)</b> <i>See also WAC 296-869</i>   |  |                               |
| Vehicle mounted aerial devices  | Regardless of height                             | 296-880-30015(2)              |
| Manually propelled and self-propelled elevating work platforms (including scissor lifts)                            | Regardless of height if required by manufacturer | 296-880-30015(3)              |
| Boom supported elevating work platforms   | Regardless of height                             | 296-880-30015(4)              |
| <b>Powered platforms</b> <i>See also WAC 296-870</i>  |  |                               |
| Working on a roof or other elevated working area  | Four feet or more                                | 296-880-30020(5)              |
| <b>Window cleaning</b> <i>See also WAC 296-878</i>  |  |                               |
| Working on a roof or other elevated working area  | Four feet or more                                | 296-880-30025(1)              |
| <b>Scaffolds</b> <i>See also WAC 296-874</i>  |  |                               |
| Working on a scaffold – supported and suspended   | Ten feet or more                                 | 296-880-30030(1)              |
| <b>Telecommunications work</b> <i>See also WAC 296-32</i>   | Four feet or more                                | 296-880-200 and 296-880-30040 |
| <b>Qualified electrical workers</b> <i>See also WAC 296-45</i>  | Four feet or more                                | 296-880-200                   |
| <b>Tree work</b> - <i>Follow best practices in ANSI Z133-2017 Safety Requirements for Arboricultural Operations</i> | Regardless of height                             | DOSH directive 20.75          |

[Back to Top](#)

## FALL PROTECTION REQUIREMENTS

---

The UW is committed to preventing falls and fall injuries by designing facilities, processes, and equipment where access to work areas can be achieved by working from the ground or floor, a platform, mobile elevating work platform, or scaffolding, and avoiding work from ladders whenever possible.

More importantly, work at elevations, where a person is not protected from falling by engineering controls, the worker must wear personal fall protection. Its use must be limited or infrequent and must be performed under the strict compliance with the work practices in this document, current regulations, standards, and industry best practices. The regulations that apply are listed in the [SCOPE](#) section. In general, employers are required to:

1. Ensure that all surfaces that employees will be working or walking on are structurally sound and will support them safely prior to allowing employees to work or walk on them.
2. Inspect all components (including hardware, lanyards, and harnesses) of personal fall arrest and restraint systems and positioning device systems prior to each use according to manufacturer's specifications for mildew, wear, damage, and other deterioration. Remove defective equipment from service if function or strength is adversely affected.
3. Inspect safety nets at least once a week for wear, damage, and deterioration, or after any occurrence that could affect the integrity of the safety net system. Remove defective components from service. *Note: The UW does not recommend the use of safety nets.*
4. Only use personal fall arrest and restraint systems, and positioning device systems and their components for employee protection and do not use to hoist materials.
5. Plan for and provide prompt rescue of employees in the event of a fall or assure the self-rescue capability of employees.

**Some fall protection systems are not recommended for use by UW employees. This includes safety nets, catch platforms, and administrative controls that rely on warning systems and safety monitors. The potential risks when using these systems may not be acceptable and therefore must require department management approval documented on the Fall Protection Work Plan. These less safe systems should only be considered as a last resort when safer systems cannot be used.**

Fall protection requirements are excluded in regulations for certain activities, including:

- Installing initial fall protection anchors prior to the start of any work activity, or disassembly after work is completed

- Inspecting, investigating, or assessing roof-level conditions or work to be performed **only on low slope roofs (4:12 or less)** prior to the start of any work activity or after all work is completed; this exemption does not apply to steep pitch roofs, where construction work is underway, or when fall protection systems or equipment are installed and available to use for pre-work and post-work inspections, investigations, or assessments. Examples of activities exempt from fall protection include:
  - Measuring a roof to determine the amount of materials needed for a project
  - Inspecting the roof for damage without removing equipment or components
  - Assessing the roof to determine what method of fall protection will be provided to employees

Examples of activities **not** exempt from fall protection include:

- Delivering, staging, or storing materials on a roof
- Persons assessing or inspecting on roofs that are considered a “hazardous slope or condition” (i.e., where footing cannot be maintained without devices due to the pitch of the surface, weather conditions, rotted wood, or surface material)
- Measuring, inspecting, or assessing in an area of a roof that is in an area close to the roof edge
- Doing assessments when other activities (e.g., working with tools, or other work is nearby) are going on and can be a distraction

## Roles and responsibilities

| <b>FALL PROTECTION - GENERAL</b> |  |
|----------------------------------|--|
| <b>Roles</b>                     | <b>Definition/Responsibilities</b>   |
| <b>Qualified Person</b>          | One who, by possession of a recognized degree, certificate, or professional standing, or who by extensive knowledge, training, and experience, has successfully demonstrated their ability to solve or resolve problems related to the subject matter, the work, or the project.   |
|                                  | <ul style="list-style-type: none"> <li>Responsible for selection, use, and installation of fall protection equipment, detailed equipment inspection, and maintenance.</li> <li>Evaluate and certify anchorages on structures.</li> <li>Design, install, and supervise use of horizontal lifelines.</li> <li>Train Authorized Persons and Competent Persons.</li> </ul>   |
| <b>Competent Person</b>          | An individual knowledgeable of fall protection equipment, including the manufacturer's recommendations and instructions for the proper use, inspection, and maintenance; and who is capable of identifying existing and potential fall hazards; and who has the authority to take prompt corrective action to eliminate those hazards; and who is knowledgeable of the rules contained in this section regarding the installation, use, inspection, and maintenance of fall protection equipment and systems                                 |
|                                  | <ul style="list-style-type: none"> <li>Receive training from Qualified Person(s) or qualified training company specialized in training Competent Persons in fall protection.</li> <li>Prepare and review Fall Protection Work Plans.</li> <li>Identify and monitor locations, activities, and tasks where fall protection is required.</li> <li>Take prompt corrective action to eliminate fall hazards.</li> <li>Train Authorized Persons and employees exposed to fall hazards.</li> <li>Identify and inspect anchorage points.</li> </ul> |
| <b>Authorized Person</b>         | A person approved or assigned by the employer to perform a specific type of duty or duties, or be at a specific location or locations at the workplace   |
|                                  | <ul style="list-style-type: none"> <li>Read and understand fall protection controls, systems, procedures, and work plans.</li> <li>Attend required training on the procedures for safely working at heights and near fall hazards, and proper use of fall protection equipment.</li> <li>Inspect and wear the appropriate fall protection personal protective equipment.</li> <li>Prepare Fall Protection Work Plans.</li> <li>Report all incidents and unsafe conditions.</li> </ul>  |



## 1. Hazard elimination

Hazard elimination is the first and best control to protect employees from fall hazards. The [UW Facilities Design Standard](#), incorporates safe access and fall protection requirements for new construction and renovations, which can eliminate fall hazards. In the design of new facilities, architects and engineers can eliminate or control fall hazards during the facilities planning stage. Examples include:

- Specifying that HVAC (heating, ventilating and air conditioning) equipment be located on the ground or in a mechanical equipment room rather than by the edge of the roof
- Designing parapet walls on rooftops to be 42 inches plus or minus 3 inches high
- Lowering a meter or valve at a high location to a worker's level or providing a chain wheel (see image) when valves are required to be at elevation

Work tasks and processes can be changed to eliminate fall hazards, including:

- Lowering the work surface to ground level
- Substituting a process, sequence, or procedure so that workers no longer approach a fall hazard
- Rather than using a ladder, an employee can use poles or extension rods fitted with tools to reach high places to do tasks from the ground, or use a mobile elevating work platform

## 2. Passive systems

Passive systems are physical barriers at fall hazards that do not require the worker to wear any personal fall protection equipment. They isolate or separate the fall hazard from workers through the use of guardrails, or by covering potential hazards, such as exposed floor holes and openings, impalement hazards and other hazards, including the following:

- **Covers at any height** are required over impalement hazards and holes.
  - Workers must be protected from falling into or onto impalement hazards, such as reinforcing steel (rebar), exposed steel, or wood.
  - Holes (two inches or more in its smallest dimension) must be covered or guarded so that a worker does not trip, step into or step through the hole. Protection must be a cover of standard strength and construction, or a standard guardrail system.



[www.babbitt.com](http://www.babbitt.com)

**Chainwheel to operate valves in high, normally out-of-reach locations**

- **Standard guardrail systems at any height** are required to guard open-sided floors, walkways, platforms, or runways above or adjacent to dangerous equipment, such as dip tanks, material handling equipment, and similar hazards.

- **Standard guardrails** are required for open-sided floors or platforms 4 feet or more above the adjacent floor or ground level. Guardrails can be placed along all exposed sides of skylights and other roof and floor openings 12 inches or more in diameter. Portable guardrail systems are also available.



**Rebar caps for impalement hazard protection**

[www.ironworkers.org](http://www.ironworkers.org)

- **Guardrail systems** must consist of a top rail, intermediate rail, toeboard as needed, and posts, and withstand a load of at least 200 pounds applied to the top edge. Specifications include:



[www.cisco-eagle.com](http://www.cisco-eagle.com)

**Standard guardrail system**

- A smooth surfaced top rail at 39 to 45 inches from the base level (floor, platform, runway, or ramp)
- An intermediate rail halfway between the top rail and base level
- A toeboard at a minimum of 3.5 inches in vertical height from the base level, or screening for large objects, when necessary to protect workers below from falling objects
- Vertical posts spaced at least every 8 feet on center

- **Covers** over holes and openings must be capable of supporting, without failure, at least twice the weight of employees, equipment, and materials that may be imposed on the cover at any one time. This includes skylights, other roof and floor holes, and floor openings. Temporary covers must be secured over the opening and be color coded or marked with the word "hole" or "cover" to warn of the hazard. Barriers used to cover openings must be secure and withstand a load of at least 200 pounds applied in any direction (except upward). Screen covers must be secure and withstand a load of at least 200 pounds applied horizontally at any point on the near side of the screen.



[www.grainger.com](http://www.grainger.com)

**Skylight cover**

- **Safety nets** and **catch platforms** are not recommended as fall protection for workers, but debris nets are acceptable to prevent falling objects.

**Note:** When a guardrail system, cover, or warning line system (see focus sheet [Using Alternative Fall Protection on Roofs](#)) must be temporarily removed to perform a specific task, an employee must remain at the opening until the guardrail system, cover, or warning line system is replaced. The only duty the employee must perform is to warn persons entering the area of the fall hazard. The employee must be protected from the fall hazard by a personal fall arrest system or personal fall restraint system.

### 3. Fall restraint and positioning device systems

Fall restraint and positioning device systems secure the worker to an anchor using a lanyard short enough to prevent the worker from reaching the fall hazard. These systems are not designed to catch or arrest a falling worker. More information and illustrations of fall restraint and positioning device systems are provided in [Appendix E](#).

Fall restraint systems, including a full body harness, lanyard, restraining lines and anchorage point, can be used by a worker to keep the worker from reaching a fall point, such as the edge of a roof or elevated work surface.



[www.3M.com](http://www.3M.com)

**Fall restraint system**



[www.3M.com](http://www.3M.com)

**Positioning system**

Positioning device systems include a full body harness with D-rings on both sides at the waist, connected to a positioning lanyard and anchorage point that is rigged so that a person can be supported on an elevated vertical or inclined surface, such as a wall, pole, or column, and work with both hands free from the body support.

If a fall arrest system is needed in addition to a positioning system, a separate arrest system must be worn by the worker that is attached to an appropriate anchor.

**Warning: Waist belts are prohibited at the UW.**

## 4. Fall arrest protection systems

Personal fall arrest protection systems are designed to stop a worker's fall after a fall has begun and prevent a worker from contacting the lower level. When properly employed, fall arrest systems nearly eliminate the risk of serious, and possibly fatal, injuries. More information and illustrations of fall arrest protection system components are provided in [Appendix E](#).

- Typical fall arrest equipment at UW includes the following:
  - **Full body harness.** The body harness distributes the force needed to stop a fall to areas of the body that are well protected by bone and muscle structure. The attachment point must be located in the center of the worker's back, near shoulder level, or above the wearer's head.
  - **Lifelines or lanyards with deceleration devices.** The deceleration devices help to absorb the resulting shock and possible injury of rapid deceleration.
  - **Anchorage points that are strong enough to support the worker.** Anchorage points must be rated at a minimum of 5000 pounds where the surrounding area is free of obstacles. Exception: An engineered system designed at two times the maximum arresting force can be allowed only if it has been designed, installed and used under the supervision of a Qualified Person. See the [ANCHORS](#) section for more information.
- To ensure the shortest, protected fall, it is recommended to use the shortest fall arrest system with a tie off point at or above your D ring. The best practice is to place the tie-off to a lifeline level with or higher than the harness connection.
- Horizontal lifelines must be designed, installed and used under the supervision of a Qualified Person (e.g., professional engineer) specializing in structural systems or a related field.
- Horizontal lifeline anchorage points (see the [ANCHORS](#) section) must support the regulated required weight per employee.
- To provide 100 percent fall arrest protection, a double tie-off or "Y"-type lanyard must be utilized to protect the worker from falling when traveling between lifelines or anchor points.
- Vertical lifelines should never have more than one person attached to any one lifeline.



[www.3M.com](http://www.3M.com)

**Fall arrest system on horizontal lifeline**

- When using vertical lifelines, knot or secure the end of the lifeline to keep from moving past the end. Knots in lanyards and vertical lifelines must be inspected by a Competent Person or Qualified Person to ensure it meets strength requirements.
- Fall arrest systems must be rigged to prevent a worker from freefalling more than 6 feet and to prevent contact with the lower level. Remember to account for the deceleration distance of 3.5 feet when using a 6 foot lanyard. See [Appendix B](#) (page 4 of the Fall Protection Work Plan) to calculate fall clearance for lanyards and self-retracting lanyards.
- Always inspect all components of the fall protection system **prior to each use**. Only Authorized Persons, who have been trained by a Competent Person, will do inspections. See [Appendix G](#) for detailed guidelines and instructions for inspecting fall protection system components prior to each use.
- Fall protection system components must also be inspected annually and documented by a Competent Person. See [Appendix C](#) for annual inspection checklists. Only use the equipment according to manufacturer recommendations. Never use incompatible equipment together.

## 5. Administrative controls

Administrative controls are work practices and procedures that signal or warn a worker to avoid approaching a fall hazard. They should only be used if all other fall protection methods described above are not possible.

Common administrative controls for fall protection on flat or low slope (4:12 or less) roofs or surfaces include:

- Warning line systems
- Safety monitor systems
- Safety watch

Warning line systems, safety monitor systems and safety watch are prohibited on steep slope roofs and surfaces (greater than 4:12). Detailed information on these systems and procedures are provided in the focus sheet [Using Alternative Fall Protection on Roofs](#).

[Back to Top](#)



## PROTECTION FROM FALLING OBJECTS

Falling objects, including tools that you or your coworkers may drop, can result in serious injuries. Even a hard hat may not provide enough protection from small tools dropped from heights. Objects and tools can fall from elevated work platforms and scaffolds on to workers below, and into floor and wall holes and openings (i.e., a gap or void two inches or more in its smallest diameter in a floor, roof, or other surface), and into trenches and excavated areas where workers are working on different levels. Regulations require one or more of the following:

- Secure tools and materials to prevent them from falling on people below.
- Barricade hazard areas and post warning signs.
- Use toeboards, screens, or mesh on guardrails or scaffolds to prevent falling objects.
- Use debris nets, catch platforms, or canopies to catch or deflect falling objects.



[www.3M.com](http://www.3M.com)

**Tape measure retractor holster**

Preventing objects from falling should be a high priority. Securing tools can be done in various ways including the use of:



[www.3M.com](http://www.3M.com)

**Tool lanyard**

- Tool lanyards
- Tool belts
- Tool holsters
- Tool pouches
- Buckets
- Wristbands
- Attachment points



[www.3M.com](http://www.3M.com)

**Tool lanyard**

Attachment points make it possible to tether most tools. Once an attachment point has been installed on a tool, a tool lanyard can be used to tie off the tool. Tool lanyards can be connected to a worker (for tools less than 5 pounds) using a tool belt, harness, or wristband, or anchored to a fixed structure. See [3M Fall Protection for Tools](#), [Gear Keeper](#), [Ergodyne](#), or [Proto](#) for more information.

Where an elevated platform, scaffold or walking-working surface is used for tasks, provide falling object protection under it by implementing the following:

- Secure objects as mentioned above.
- Wear personal protective equipment (PPE), including a hard hat and safety glasses (at a minimum).

- Move large or heavy objects on the platform away from the edge and secure to the platform.

In addition, do one of the following:

- Install toeboards (minimum 3.5 inches in height), screen or mesh from the floor to the top guardrail around the perimeter of the platform; **or**

***(NOTE: Higher barriers are required in areas where objects can fall over a toeboard. Where tools, equipment, or materials are piled higher than the top edge of a toeboard, paneling or screening must be erected from the walking or working surface or toeboard to the top guardrail).***

- Provide signage with regulatory language and warning lines or a barricade to notify all personnel under or around the platform to stay away from the area; **or**
- Erect a canopy, debris net, or other structure capable of protecting employees under and around the platform.

[Back to Top](#)

## FALL PROTECTION WORK PLAN

---

A Fall Protection Work Plan is required when working at heights of 10 feet or more. A template work plan is provided in [Appendix B](#). The [Fall Protection Work Plan](#) is a fillable form Word document that is also available on the EH&S website. Work activities at heights that may not require a Fall Protection Work Plan are shown in the [Fall Protection Work Plan Requirements table](#).

- An Authorized or Competent Person must complete the Fall Protection Work Plan and submit it to a Competent Person for review. The name of the Competent Person who reviewed the work plan must be documented on the work plan.
- The Supervisor or a designee must approve, sign, and date the work plan prior to the start of work.
  - Fall Protection Work Plans where an engineered fall protection system designed to not exceed a maximum arresting force of 1800 pounds must be approved and signed by a Qualified Person.
  - Work plans that include administrative controls must be approved and signed by department management.
- A work plan must be in place **prior to** performing the work at heights.
- The work plan must provide the following information at a minimum:
  - Type of work and associated fall hazards
  - Type of fall protection system to be used and procedures for setup, inspection, ongoing monitoring, and removal
  - Procedures for how the tools and equipment will be secured or how overhead protection will be provided for workers who are working in or pass through the area below the work
  - Method planned for prompt, safe rescue and removal of injured workers
  - Assurance that the fall protection equipment has been inspected prior to putting into service
  - Signature and date
- Authorized personnel must read, sign, and date each work plan applicable to their job duties.
- The work plans will be kept in a designated area for each facility or department that has personnel performing work at heights and available at the job site for inspection.
- New work plans must be reviewed and approved by both a Competent Person and Supervisor or Lead.



- Changes to an existing work plan must be reviewed and approved by both a Competent Person and Supervisor or Lead.
- Existing work plans should be reviewed after an incident occurs and annually to determine whether hazards have changed.
- Completed Fall Protection Work Plan documents must be retained for at least one year and available for auditing purposes.

[Back to Top](#)

## FALL PROTECTION EQUIPMENT

---

All fall protection equipment must meet the American National Standards Institute (ANSI)/ASSE Z359 Fall Protection Code, the national voluntary consensus fall protection equipment standard for general industry, and applicable Washington state regulations. See [Appendix F](#) for illustrations and descriptions of common fall protection equipment that is used at the UW.

Assembly and disassembly of all equipment must be done according to manufacturers' recommended procedures. This includes donning the harness according to the manufacturer's directions and attaching the lanyard to the identified anchor point.

- Store fall protection equipment in a secure, dry environment, free of exposure to fumes or corrosive environments that can damage the equipment.
- Visually inspect all personal fall protection equipment before each use. See [Appendix G](#) for fall protection equipment inspection guidelines.
- An annual documented inspection must be performed by a Competent Person for all fall protection equipment. See [Appendix C](#) for inspection checklist templates. Fillable form Word documents of inspection checklists are on the [EH&S website](#).
- Any defective equipment must be tagged and removed from use immediately.
- Clean equipment per manufacturer's instructions.
- Remove from service any element of a personal fall protection system that was subjected to impact loading (i.e., high force or shock applied over a short time period) so they can be inspected by a Competent Person for appropriate action. This includes anchors, harnesses, lanyards, connecting components, among others.

[Back to Top](#)

## ANCHORS

---

In fall protection, an anchor is an engineered and designed point of attachment for lifelines, lanyards, and deceleration devices. For personal fall arrest systems, anchorages must be capable of supporting at least 5,000 pounds for each person attached, or must be designed, installed, and used as part of a complete personal fall arrest system that maintains a safety factor of at least two, under the supervision of a Qualified Person.

### Anchor types

Anchors may be temporarily mounted or permanently installed. Pictures and information about types of various anchors are provided in [Appendix E](#). Examples include:

- **Permanent anchors**, such as roof or wall mounted anchors permanently attached to the building structure
- **Temporary anchors**, such as anchor straps, friction bolts, beam clamps and trolleys attached to structural beams, and free standing mobile anchors with weights
- **Horizontal lifelines** are suspended between two anchorage points, and a connector of a personal fall arrest or restraint system is connected to the line. They must be designed, installed, and their use overseen by a Qualified Person.
- **Vertical lifelines** are suspended from a top anchorage point and a stop at the bottom. A personal fall arrest system is connected to the line with a rope grab connector that is designed to move up and down a vertical lifeline when in the open position and to grab the line in the event of a fall.



www.guardian.com

**Permanent roof anchor**

### Anchor strength requirements

Permanent anchors should be based on the designs shown in the [UW Facilities Design Standard](#). Structural analysis of alternate systems (e.g., engineer-certified anchor points) must be provided and approved by a Qualified Person. Key requirements include:

- It is UW policy that all anchors, including those designed as part of a fall restraint system, must be designed to fall arrest requirements to avoid confusion and the potential for a fall restraint anchor to be used for fall arrest.
- The design, fabrication, and installation of every fall arrest system, including all anchors and lifelines, are the responsibility of the design consultant and must comply with codes and standards. Fall arrest anchors and their attachment to the building must be of materials that will not rot, corrode, or deteriorate in any way. Locations of the anchors must be approved by a Qualified Person prior to completion of building design.

- Anchorage points for engineered fall arrest systems must not exceed a maximum arresting force (MAF) of 1800 pounds and must be designed, installed, and used under the supervision of a Qualified Person.

When choosing a temporary anchor point, a steel supporting member is preferable. Wood may be acceptable as a temporary anchor, but must be engineer-certified. Anchor bolts should be inspected by a Qualified Person, as should through-bolts and plate washers. Equipment, such as eyebolts, turnbuckles, imbeds, beam clamps, etc., may also be used with temporary anchors and should be carefully inspected and evaluated for load bearing capacity.

Structures and items that should NEVER be used as anchorage points include:

- Standard guardrails\*
- Wiring harnesses
- Standard railings
- Rebar
- Ladders/rungs\*\*
- Lanyards
- Unistrut\*
- Vents
- Light fixtures
- Fans
- Conduit or plumbing
- Roof stacks
- Ductwork or pipe vents
- Any item or structure not capable of meeting required structural load requirements

\*Unless certified by the manufacturer or permitted after review and approval by a Competent Person

\*\*Exception: fixed ladder used for positioning anchorage point

Anchorage strength requirements are dependent on specific applications as shown below. These requirements apply to all anchors, permanent and temporary.

| Fall Protection System                                       | Certified Anchor                | Non-Certified Anchor | As defined by        |
|--|---------------------------------|----------------------|----------------------|
| Fall arrest  | 2 times maximum arresting force | 5,000 pounds         | WAC, OSHA, ANSI/ASSE |
| Work positioning   | 2 times foreseeable force       | 3,000 pounds         | OSHA, ANSI/ASSE      |
| Fall restraint and travel restriction                        | 2 times foreseeable force       | 1,000 pounds         | ANSI/ASSE            |
| Rescue (retrieval only)                                      | 5 times applied load            | 3,000 pounds         | ANSI/ASSE            |
| Horizontal lifeline  | 2 times maximum line load       | Not applicable       | OSHA, ANSI/ASSE      |
| Suspended Maintenance Operations*                            | Certified Anchors Only          |                      | As defined by        |
| Suspended scaffold, rope descent system or similar equipment | 2 times maximum arresting force | 5,000 pounds         | WAC, OSHA, ANSI/IWCA |
| Personal fall arrest system                                  | 2 times maximum arresting force | 5,000 pounds         | WAC, OSHA, ANSI/IWCA |

\*Includes window cleaning, caulking, metal polishing, re-glazing, and general maintenance on building surfaces

### Definition of “Certified Anchorage”

An anchorage for fall arrest, positioning, restraint, or rescue systems that a **Qualified Person certifies** to be capable of supporting the potential fall forces that could be encountered during a fall or that meet the criteria for a certified anchorage defined in regulations and standards

### Definition of “Non-Certified Anchorage”

An anchorage for fall arrest, positioning, restraint, or rescue systems that a **Competent Person can judge** to be capable of supporting the predetermined anchorage forces as defined in regulations and standards

## Certifications and inspections of anchors

An initial inspection report and load capacity of a permanent anchor must be provided by the manufacturer or installer of the equipment. If this information is not available, an “Initial” inspection must be performed by a licensed professional engineer that includes:

- Collecting pertinent information pertaining to the building
- Reviewing applicable drawings, engineering data, and other documentation
- Visually inspecting and assessing the condition of existing window cleaning/suspended maintenance installations and fall protection anchor systems as installed at a building
- Analyzing the structure of existing window cleaning/suspended maintenance installations and fall protection anchor systems as installed at a building
- Analyzing the structure of existing roof parapets and guardrails subjected to the direct loading of suspension lines

Regulations and standards require that all anchor points and completed equipment installations are inspected by a Competent Person:

- Before being placed into initial service
- Following any major alteration to an existing installation
- At intervals not exceeding 12 months
- At intervals specified by the manufacturer/supplier, but not exceeding 12 months

The certification/inspection record must include the date of the inspection, the signature of the person who performed the inspection, and the number, or other identifier, of the building support structure and anchorage equipment that was inspected. These records must be retained by the building owner, or building manager (if it is a leased building). A template Anchor Annual Inspection Checklist is provided in [Appendix C](#). A fillable form Word document is available on the [EH&S website](#).

## Labeling and records

Anchorage points should be labeled with:

- Manufacturer's name (if custom made, any identifying information)
- Model and serial number
- Maximum load
- Appropriate ANSI/Occupational Safety and Health Administration (OSHA) markings
- Current inspection date and the date of first use

If this information is not available, there should be some identification marking to determine the history and records of the anchorage through UW Facilities. An anchorage that has failed inspection or been involved in a fall must be tagged or rendered so it cannot be used. Records of all anchor certifications, annual inspections and repairs must be documented and retained for the lifetime of the anchor.

## WALKING-WORKING SURFACES

---

A walking-working surface (see [Appendix A Definitions](#)) is any horizontal or vertical surface on or through which an employee walks, works or gains access to a work area or workspace location. Walking-working surfaces exist across campus in or near offices, shops, laboratories, and other work areas. When faculty, staff, students, and visitors use walking-working surfaces, they must be protected from fall hazards. Falls from heights and on the same level historically are among the leading causes of serious work-related injuries and deaths. Note that applicable local building codes must be met in addition to the state regulations cited below.

Refer to the [Fall Protection Trigger Heights](#) table for specific fall protection required for walking-working surfaces at any height, at four feet and above, and at other heights. General requirements addressed in [WAC 296-24-73505 Walking-Working Surfaces](#), require the following:

### **Surface conditions:**

- Keep surfaces in a clean, orderly, and sanitary condition. This includes all places of employment, passageways, storerooms, service rooms, and walking-working surfaces. Note: "Sanitary condition" covers hazard exposures other than slips, trips, and falls, including prevention of illness or disease, and fire or explosion resulting from combustible dust.
- Maintain workroom floors in a clean and dry condition. For wet processes, maintain drainage, and if feasible, dry standing places, such as platforms and by using mats.
- Maintain walking-working surfaces free of hazards, such as sharp or protruding objects, loose boards, corrosion, leaks, spills, snow, and ice.

### **Surface load and access:**

- Ensure that the surface supports the maximum intended load for that surface.
- Provide, and ensure employees use, a safe means of access and egress to and from the surface.

### **Surface inspection, maintenance, and repair:**

- Walking-working surfaces must be inspected, regularly and as necessary, and be maintained in a safe condition.
- Hazardous conditions must be corrected or repaired before an employee uses the walking-working surface again. If not made immediately, the hazard must be guarded until corrected or repaired.
- When correction or repair involves the structural integrity of the surface, a Qualified Person must perform or supervise the correction or repair.

Walking-working surfaces that must be regularly inspected include general work environments, walkways, floor and wall openings, stairs and stairways, elevated surfaces, and loading docks. Details of inspection requirements are listed in the Walking-Working Surfaces Inspection Checklist template provided in [Appendix C](#). A fillable form Word document is available on the [EH&S website](#).

## Stairs and stairways

In addition to the requirements described above for walking-working surfaces, all stairs require the following under General requirements for all stairs in [WAC 296-24-74005](#):

- Provide handrail and stair rail systems in accordance with [WAC 296-24-74015](#). See [Appendix D](#) for details and diagrams.
- Provide vertical clearance above any stair tread to any overhead obstruction of at least 6 feet, 8 inches, as measured from the leading edge of the tread. Spiral stairs must meet vertical clearance requirements in [WAC 296-24-74020](#).
- Stairs must have uniform riser heights and tread depths between landings.
- Stairway landings and stair platforms must be at least the width of the stair and at least 30 inches in depth, as measured in the direction of travel.
- When a door or gate opens directly on a stairway, a stair platform must be provided, and the swing of the door or gate must **not** reduce the stair platform's effective usable depth to:
  - Less than 20 inches for platforms installed before October 1, 2020
  - Less than 22 inches for platforms installed after October 1, 2020
- Each stair must support at least five times the normal anticipated live load, but never less than a concentrated load of 1,000 pounds applied at any point.
- Standard stairs (see [WAC 296-24-74010](#)) must be used to provide access from one walking-working surface to another when operations require regular and routine (once per week) travel between levels, including access to operating platforms for equipment. Winding stairways may be used on tanks and similar round structures when the diameter of the tank or structure is at least 5 feet.
- Spiral, ship, or alternating tread-type stairs must only be used when it is not feasible to provide standard stairs. When allowed, they must be installed, used, and maintained in accordance with manufacturer's instructions.
- Each tread and the top landing of a stairway, where risers are used, should have a nose which extends 1/2 inch to one inch beyond the face of the lower riser.
- Stair tread noses should have an even leading edge.

Stairways having four or more risers or rising more than 30 inches, whichever is less, must be equipped with at least one handrail and one stair rail system along each unprotected side or edge. See details and diagrams of requirements for stairs and stairways in [Appendix D](#).



## LADDERS

---

Falls from ladders are one of the leading causes of occupational injuries. Instead of using a ladder to access or work at an elevated height, consider using a mobile scaffold or mobile elevating work platform. If a ladder must be used for a job, select the appropriate ladder, inspect it thoroughly, and use it properly.

Regulations covering ladders are addressed in [WAC 296-876 Ladders, Portable and Fixed](#), and they apply to portable and fixed ladders (including job-made wooden ladders), mobile ladder stands, and mobile ladder stand platforms. For fall arrest harness, rope/cable grab, and similar requirements related to ladder safety systems used on fixed ladders, the unified fall protection rule in [WAC 296-880](#) applies (see [FALL PROTECTION REQUIREMENTS](#) section).

If a fall hazard is identified for a ladder job, a Fall Protection Work Plan may be required and a personal fall protection system may be needed to do the job safely.

See the Hierarchy of Equipment Selection for Working at Heights below for alternatives to using ladders. The most safe ladder alternatives are located at the top of the figure (in the “work from the ground” section) and the less safe ladder options are located at the bottom of the figure.

[Back to Top](#)

**Hierarchy:**

**Equipment Selection  
for Working at Heights  
- Ladder Alternatives**

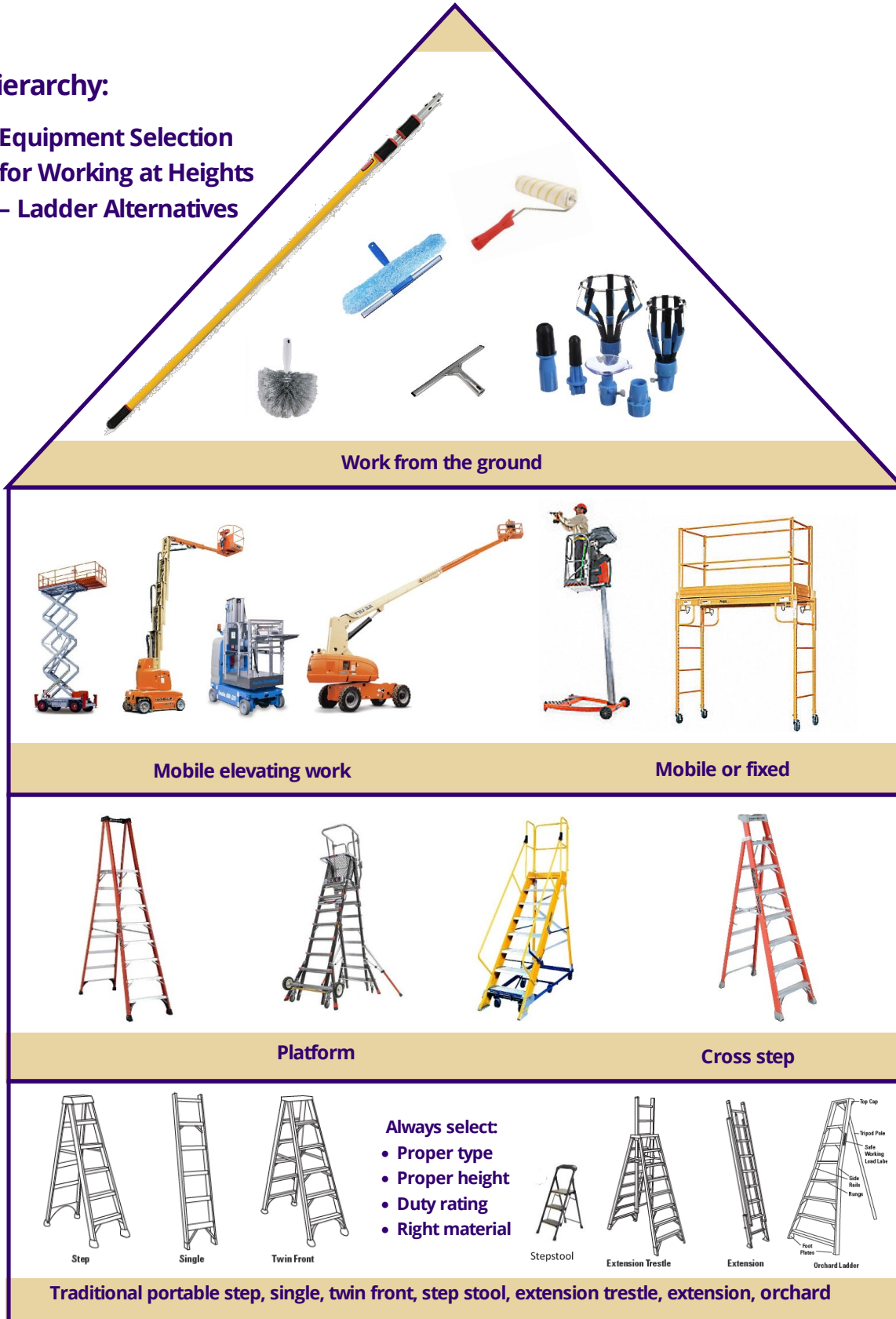

## Roles and responsibilities

| FALL PROTECTION - LADDERS |  |
|---------------------------|--|
| Roles                     | Definition/Responsibilities  |
| <b>Competent Person</b>   | An individual knowledgeable of ladders, including the manufacturer's recommendations and instructions for the proper use, inspection, and maintenance; and who is capable of identifying existing and potential ladder hazards; and who has the authority to take prompt corrective action to eliminate those hazards; and who is knowledgeable of the rules contained in this section regarding the installation, use, inspection, and maintenance of ladders   |
|                           | <ul style="list-style-type: none"> <li>• Identify and monitor locations, activities and tasks where ladders are used and fall protection systems may be required.</li> <li>• Inspect ladders.</li> <li>• Prepare and review Fall Protection Work Plans.</li> <li>• Train employees.</li> </ul>   |
| <b>Employee</b>           | <ul style="list-style-type: none"> <li>• Read and understand portable and fixed ladder procedures, fall protection controls, systems, procedures, and work plans.</li> <li>• Attend required training on the procedures for safely working with ladders, working at heights and near fall hazards, and proper use of fall protection equipment when required.</li> <li>• Inspect ladders.</li> <li>• Prepare Fall Protection Work Plans.</li> <li>• Report all incidents and unsafe conditions.</li> </ul> |

Typical ladders at the UW include portable self-supporting step ladders, and non-self-supporting straight and extension ladders. Of these types of ladders, only fiberglass or plastic reinforced ladders that conform to ANSI ladder standards are permitted at the UW. Fixed ladders at the UW are permanently attached to a structure, building or equipment in exterior and interior locations. Stepstools, widely used at UW, should be ladder-type, and meet current safety standards. See the [Ladder Safety focus sheet](#) on the [EH&S website](#) for additional information.

### Portable ladder selection

Select the best ladder for the job. Consider the target work zone and evaluate the following criteria.

- **Ladder type:** Use the appropriate ladder for the surface it is placed on and the work that is to be done. For example, a closed step ladder should not be leaned against a wall to do work or gain access to another level, unless it is specifically designed to do so (e.g., Louisville Cross Step and Werner LEANSAFE). Also, orchard

ladders should only be used in orchards or for outdoor landscaping work and should not be used as a step ladder. Platform ladders that have guarded platforms at the top are safer by design than typical step ladders.

- **Ladder use area:** Self-supporting (step ladders) have a fixed dimension while non-self-supporting ladders will require a 4:1 height-to-base distance from the wall and at least a 3 foot extension above the landing or working surface.
- **Ladder conditions:** Ensure that overhead obstructions (e.g., electrical lines require at least 10 feet of clearance) do not interfere with work or create a hazard when working from the ladder. Ensure area below or on the ground does not contain obstructions that would interfere with ladder placement.
- **Ladder working load:** The working load must never exceed the ladder duty rating, shown on the ladder label. The working load is the total weight of the worker (including PPE), tools, equipment, and material used when working from the ladder.
- **Ladder height:** The ladder height selected to reach the target zone can be determined by adding the highest allowable standing height (approved by the ladder manufacturer) to the worker's height (measured from feet to shoulders), plus a maximum reach distance of 12 inches.
- **Climbing or descending a fixed or portable ladder at heights less than 24 feet when used only as a means of access to a different level:** This requires the employee to utilize both hands and both feet for the sole purpose of climbing or descending the ladder (i.e., do not carry anything while climbing or descending).

## Stepstools

Ladder-type stepstools are regulated under portable ladders. Many times they are safer to use than other types of stepstools when used in areas such as offices, storage rooms, and laboratories. They have duty ratings and load capacities as other portable ladders, so selection should be based on the planned use. They are usually foldable.



**Ladder-type stepstool**



**Ladder-type stepstool**

A stepstool is defined in WAC regulations as a self-supporting, portable ladder that has flat steps and side rails. Stepstools include only those ladders that have a fixed height, do not have a pail shelf, and do not exceed 32 inches in overall height to the top cap, although side rails may extend above the top cap. A stepstool is designed so an employee can climb and stand on all of the steps and the top cap. Steps are spaced not less than 8 inches apart and not more than 12 inches apart measured between the centerlines of the steps. Stepstools have a minimum clear width of 10.5 inches.

When selecting ladder-type stepstools ensure they are ANSI/OSHA certified.

## Ladder inspection

Portable ladders must be inspected by a Competent Person when first placed into service, annually, when damaged by impact or tipping over, or when exposed to excessive heat, such as a fire. Fixed ladders must be inspected periodically. The inspection must be documented and any deficiencies corrected before being placed back into service. An Annual Portable Ladder Inspection Checklist template is provided in [Appendix C](#). A fillable form Word document Annual Portable Ladder Inspection Checklist is available on the [EH&S website](#). Supervisors must ensure that inspections are conducted as required and documentation retained.

Before each use, workers must inspect portable ladders for the following:

| LADDER COMPONENT                   | CHECK COMPONENT FOR:  |
|------------------------------------|---|
| <b>Entire ladder</b>               | <ol style="list-style-type: none"> <li>1. Missing or loose bolts, rivets, labels, or fasteners</li> <li>2. Proper spreader bar function</li> <li>3. Damage to braces</li> <li>4. Damage to pail shelves (when applicable)</li> <li>5. Stability - open the ladder and fully engage the spreader bars. Place the ladder on a level surface and check that the ladder does not rock or wobble.</li> <li>6. Contamination such as oil, grease, or mud</li> </ol> |
| <b>Side rails</b>                  | <ol style="list-style-type: none"> <li>7. Deformation, breaks, cracks, holes, dents, or splits</li> </ol>   |
| <b>Feet end caps, safety shoes</b> | <ol style="list-style-type: none"> <li>8. Presence of damage</li> <li>9. Missing feet end caps</li> </ol>   |
| <b>Steps &amp; rungs</b>           | <ol style="list-style-type: none"> <li>10. Deformation, breaks, cracks, holes, dents, or splits</li> <li>11. Missing treads</li> </ol>  |
| <b>Rope (extension ladders)</b>    | <ol style="list-style-type: none"> <li>12. Burns, tears, cuts, or frays</li> <li>13. Excessive wear</li> </ol>  |

Do not use the ladder if any component listed above fails inspection.

Ladders that fail inspection must be tagged and immediately removed from service. Proper disposal of an unsafe ladder should make it impossible for someone else to pick it up and use it. According to ANSI and the American Ladder Institute, proper disposal involves cutting the ladder vertically down the middle of the rungs before disposing.

## Ladder use

- Keep ladders free of oil, grease, or other slippery materials.
- Keep the area around the top and bottom of ladders clear.
- Do not use the top step and top cap of a step ladder as a step.

- Do not use the top four rungs of straight and extension ladders as steps.
- Position straight and extension ladders so that the top of the ladder extends at least 3 feet beyond the desired landing or working surface to provide a hand hold for getting on and off the ladder. Secure ladders at the top of the landing or working surface. Have a second person support the ladder if securing is not possible.
- Place straight and extension ladders against the wall at an angle so that the base of the ladder is one foot away from the wall for every four feet of height.
- Wear shoes with non-slip soles, free of materials, such as mud, oil and grease.
- On loose soil or a soft base, use a ladder leveler or self-leveling feet attached to the ladder. On a firm base, set ladder feet level and place on rubber pads.

### **While climbing or descending:**

- Maintain three points of contact. Grasp the ladder with at least one hand.
- Face the ladder.
- Do not carry objects or loads that could cause loss of balance or a fall while climbing up or down the ladder.
- Do not carry objects in hands, if possible. Use a tool belt, backpack or pouch attached to belt or other means to carry objects hands-free. Raise and lower heavy, awkward loads with a hand line or a hoist when positioned at the working level. Consider fall protection as needed.
- Face ladder while performing work activities. Never overreach to perform work.

### **Fall protection on a portable ladder**

Before using fall protection on a conventional portable step ladder, consider safer access such as a mobile elevating work platform (MEWP), scaffold, or portable platform ladder. See the [MEWP](#) and [SCAFFOLDS](#) sections for more information. If safer access is not possible, a personal fall arrest, restraint, or positioning system is required while using a ladder:

- Any time a worker is on a ladder more than 24 feet off the floor
- Working on a ladder at or above 10 feet from the floor (to the worker's feet) where both hands are occupied with a task. Some short-term light work may be permitted if it does not affect maintaining balance on ladder. A Competent Person should review and approve the Fall Protection Work Plan before work begins.
- If the worker is turned around on the ladder, or an excessive amount of reaching or leaning is necessary to conduct the task. An excessive amount of reaching or leaning is generally when the center of the chest (i.e. the sternum) is outside of the ladder side rails.

The anchor point for personal fall protection on a ladder must be determined by a Competent Person, be located overhead, and meet the requirements for anchors in the [ANCHORS](#) section.

Refer to the section [FALL PROTECTION REQUIREMENTS](#) if fall protection is needed on a ladder.

## Fixed ladders

Existing fixed ladders taller than 20 feet must have a cage, well, ladder safety system, or personal fall arrest system for fall protection. Cages must begin between 7 and 8 feet from the ground or lower level and extend 42 inches above the top of the landing.

Landing platforms, equipped with standard guardrails and toeboards, may be required at 20 to 30 foot intervals on tall ladders.

Regulation changes in January 2017 call for phasing out cages and wells on existing fixed ladders taller than 24 feet now through November 2036.

As of November 2018, a personal fall arrest system or ladder safety system or device will be used to replace any damaged or nonfunctioning section, cage or well previously installed on a fixed ladder. New fixed ladders will no longer be allowed to have cages or wells as the sole means of fall protection. Tower, water tank, and chimney ladders are exempted.

All fixed ladders must comply by November 2036.

Employees using new fixed ladder safety systems must be trained by a Competent Person in the Fall Protection Program in proper use and inspection procedures.

An Annual Fixed Ladder Inspection Checklist template is provided in [Appendix C](#). A fillable form Word document is available on the [EH&S website](#). Supervisors must ensure that inspections are conducted as required and documentation retained.



www.3M.com

**Fixed ladder safety system**



## Manhole steps

Manhole steps are defined as steps that are individually attached to, or set into, the wall of a manhole structure.

In addition to the Walking-Working Surface Rule ([WAC 296-24-73505](#)) requirements and the relevant fixed ladder standard requirements ([WAC 296-876](#)), manhole step requirements in [WAC 296-876-90010](#) must be followed.



Manhole steps  
(polypropylene copolymer/steel bar)  
[www.environmental-expert.com/products/iverna-2000-model-manhole-steps](http://www.environmental-expert.com/products/iverna-2000-model-manhole-steps)

## Step bolts

Step bolts are installed on masts on vessels, towers, and pole structures.



Step bolts on tower  
[Tuf-Tug Products](#)

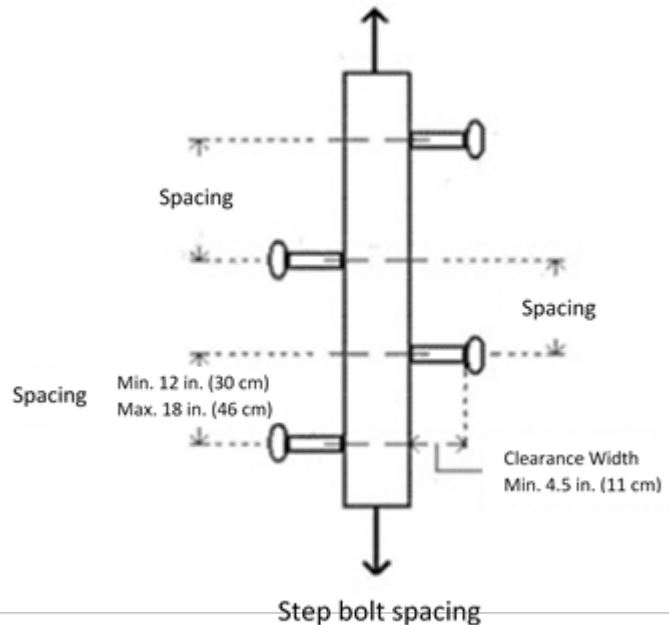

In addition to the Walking-Working Surface Rule ([WAC 296-24-73505](#)) requirements, and relevant fixed ladder requirements ([WAC 296-876](#)), step bolt requirements in [WAC 296-876-90005](#) must be followed.



### Individual-rung ladders

An individual-rung/step ladder is a fixed ladder consisting of individual steps or rungs mounted directly to the side or wall of the structure, building, or equipment. An individual-rung ladder does not include manhole steps.

Requirements for individual-rung/step ladders are given in [WAC 296-876-60030](#) in the fixed ladders section.

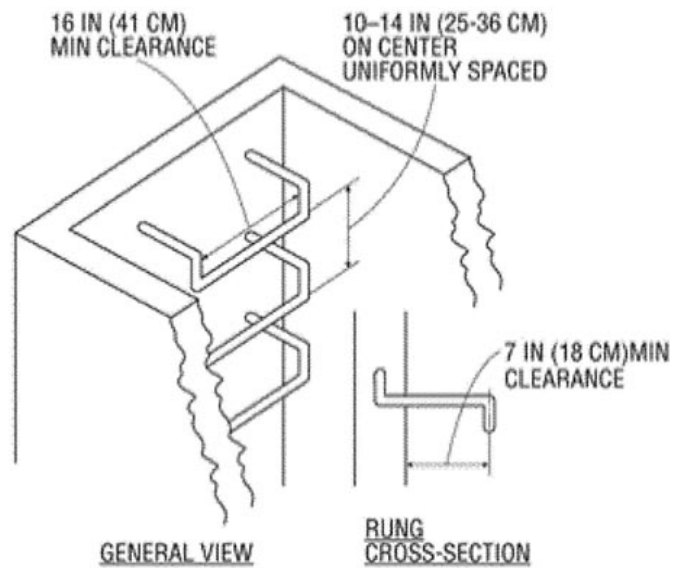

Individual-rung ladder

### Mobile ladder stands and platforms

General requirements for mobile ladder stands and platforms are given in [WAC 296-876-91005](#) in the fixed ladder rules section.

Design requirements for mobile ladder stands are given in [WAC 296-876-91010](#).

Design requirements for mobile ladder stand platforms are given in [WAC 296-876-91015](#).

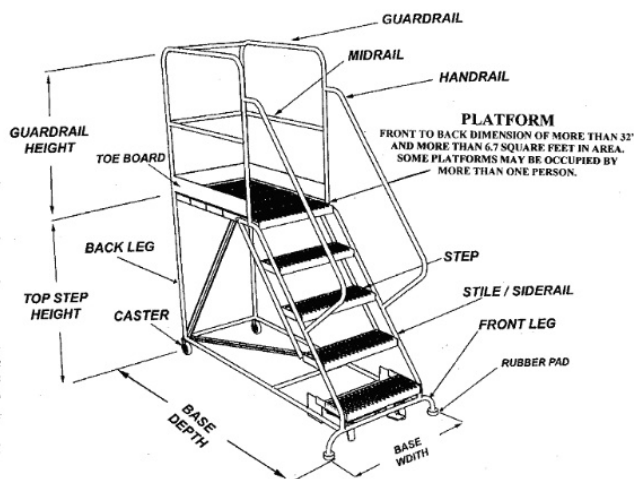

Mobile ladder stand platform  
[American Ladder Institute](#)

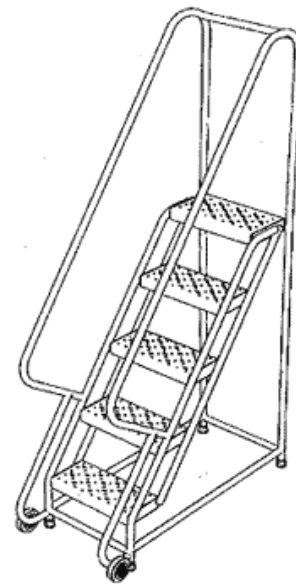

Mobile ladder stand  
[American Ladder Institute](#)

## Ladder training

Employees must be trained to recognize ladder hazards and the procedures to minimize these hazards.

A Competent Person in ladders must train employees that use ladders regularly in their work in at least the following topics:

- The proper construction (if applicable), use, placement, and care in handling ladders
- The maximum intended load capacities of ladders that are used
- Inspection prior to use
- Procedures for using portable ladders and fixed ladders
- Climbing and descending, and performing work while on ladders
- When and how to use fall protection on a ladder

Employees must be retrained as necessary to make sure they know and understand the content of the original training.

### [Ladder Safety - Online \(25 minutes\)](#)

This training course teaches employees about ladder hazards and consistent use of safe work practices. After completing the course, employees will understand common hazards of ladder use, recognize types of ladders, requirements for use, fall prevention techniques, and how to inspect ladders before and after use to ensure safe use. Retake the class as a refresher or as required by a supervisor.

### **Intended Audience**

UW Facilities employees or any UW employee who frequently uses ladders

[Back to Top](#)

## SCAFFOLDS

Scaffolds are temporary elevated platforms that support employees or materials and can be supported or suspended. Supported scaffolds can consist of one or more platforms supported by rigid means, such as outrigger beams, brackets, poles, legs, uprights, posts, or frames. Mobile scaffolds are supported scaffolds that are on casters or wheels.

### Roles and responsibilities

| FALL PROTECTION - SCAFFOLDS |   |
|-----------------------------|---|
| Roles                       | Definition/Responsibilities   |
| <b>Qualified Person</b>     | A person who has successfully demonstrated the ability to solve or resolve problems related to the subject matter, work, or project either by:<br>Possession of a recognized degree, certificate, or professional standing; or, extensive knowledge, training, and experience   |
|                             | <ul style="list-style-type: none"> <li>• Design scaffold and ensure load does not exceed designed load rating.</li> <li>• Review and approve modified components to intermix.</li> <li>• Provide a structurally sound scaffold.</li> <li>• Review anchor pull test results.</li> <li>• Train employees and Competent Persons on scaffold safety.</li> </ul>   |
| <b>Competent Person</b>     | Someone who:<br>Is capable of identifying existing and predictable hazards in the surroundings or working conditions which are unsanitary, hazardous, or dangerous to employees, and<br>Has the authority to take prompt corrective measures to eliminate them  |
|                             | <ul style="list-style-type: none"> <li>• Receive training from a Qualified Person(s) or qualified training company specialized in training Competent Persons in scaffold safety and fall protection.</li> <li>• Supervise erection, dismantling, moving, and alteration of scaffolding.</li> <li>• Prepare and review Fall Protection Work Plans.</li> <li>• Determine feasibility of providing fall protection for persons erecting or dismantling supported scaffolds.</li> <li>• Review anchor pull test results.</li> <li>• Inspect scaffolds before each use and document.</li> <li>• Take prompt corrective action to eliminate fall hazards.</li> <li>• Identify and monitor locations, activities and tasks where fall protection is required.</li> <li>• Train employees on scaffold safety and fall protection equipment when required on scaffolding.</li> </ul> |

|                 |  |
|-----------------|--|
| <b>Employee</b> | <ul style="list-style-type: none"> <li>• Read and understand scaffold systems, fall protection controls and systems, procedures, and work plans.</li> <li>• Attend required training on the procedures for safely working on scaffolds, working at heights and near fall hazards, and proper use of fall protection equipment when required.</li> <li>• Inspect and wear the appropriate fall protection PPE as needed.</li> <li>• Prepare Fall Protection Work Plans.</li> <li>• Report all incidents and unsafe conditions.</li> </ul> |
|-----------------|--|

To prevent movement, scaffolding with a height-to-base ratio greater than 4:1 must be secured to a permanent building or structure at intervals not to exceed 30 feet horizontally and 20 feet vertically. Walls that support exterior scaffold must be capable of supporting the weight of the scaffold and four times the maximum intended load on the scaffolding. Scaffolding must be fully planked with the planks secured so they cannot move. Careful consideration of wind load should be considered in the design of wrapped scaffolds.

It is a UW requirement that supported scaffolds (attached to a building or structure) that are fabricated frame scaffolds must be designed by a professional engineer with a current license in the state where the scaffolding is being erected. The erection of the engineered scaffold must be in accordance with [WAC 296-874-400](#).

A representative number of anchors installed (best practice is 10 percent) must be pull tested to verify the load design requirements have been met. Documentation of the pull tests must be provided to the Qualified Person(s) and Competent Person(s) responsible for the scaffolding design, erection, and use.

Scaffolds must be constructed, moved, altered, and dismantled in accordance with regulatory requirements by experienced staff and under the supervision of a scaffolding Competent Person.

A scaffolding Competent Person will inspect the scaffolding and ensure its safety before anyone uses it to perform work. The scaffolding must be re-inspected by a Competent Person between shifts or daily. Each inspection must be documented on the scaffolding using a tag provided by the erector. A Scaffolding Daily Inspection Checklist template is provided in [Appendix C](#). A fillable form Word document is available on the [EH&S website](#).

Scaffolds that do not pass inspection must be tagged out of service until the applicable repairs are made.

General fall protection requirements when using scaffolding include:

- Footing must be rigid and capable of carrying the maximum intended load.
- Access ladders or equivalent safe access to working levels must be provided.

- Scaffolds that are more than 10 feet high must have standard guardrails, midrails, and toeboards or netting. Cross members may be used as top or mid guardrails, but not both.
- If guardrails cannot be installed, then an external personal fall arrest system must be used with an overhead anchor point.
- Guardrails must not be used as an anchor point for a personal fall arrest system, unless the scaffold manufacturer specifies this is acceptable.

Scaffolds must not be moved horizontally while employees are on them, unless specifically designed for such movement or is an exempted mobile scaffold that meets requirements.

Employees must not work on scaffolds during storms, high wind, or when the working surfaces are covered with ice.

[Back to Top](#)

## MOBILE ELEVATING WORK PLATFORMS (MEWPS)

University personnel must comply with requirements in [WAC 296-869](#) and ANSI A92 when operating owned or leased mobile elevating work platform (MEWP) equipment. MEWPs include:

- Scissor lifts and vertical personnel lifts, where the elevating work platform cannot be positioned beyond the base of the unit
- Aerial lifts, and boom, telescoping, and articulating lifts, where the work platform can be positioned beyond the base of the unit

### Roles and responsibilities

| FALL PROTECTION – MOBILE ELEVATING WORK PLATFORMS (MEWPs) |   |
|---|---|
| Roles   | Definition/Responsibilities   |
| <b>Competent Person</b>                                   | Someone who:<br>Is capable of identifying existing and predictable hazards in the surroundings or working conditions which are unsanitary, hazardous, or dangerous to employees, and<br>Has the authority to take prompt corrective measures to eliminate them  |
|   | <ul style="list-style-type: none"> <li>• Have training, experience and knowledge in MEWPs</li> <li>• Have the authority to take prompt corrective action to eliminate fall hazards</li> <li>• Identify and monitor locations, activities, and tasks where fall protection is required.</li> <li>• Prepare and review Fall Protection Work Plans.</li> <li>• Conduct annual inspections of MEWPs.</li> <li>• Identify and inspect anchorages points on MEWPs.</li> <li>• Train employees on MEWPs.</li> </ul>  |
| <b>Employee</b>   | <ul style="list-style-type: none"> <li>• Have training, experience and knowledge in MEWPs</li> <li>• Read and understand MEWP manuals and equipment, fall protection controls and systems, procedures and Fall Protection Work Plans.</li> <li>• Attend required training on the proper use of MEWPs, working at heights and near fall hazards, and fall protection equipment.</li> <li>• Inspect and wear the appropriate personal fall protection equipment as required.</li> <li>• Inspect MEWPs before each use.</li> <li>• Prepare Fall Protection Work Plans.</li> <li>• Report all incidents and unsafe conditions.</li> </ul> |

## Scissor and personnel lifts

Scissor and personnel lifts may be self or manually propelled. Guardrails are the primary means of fall protection. Personal fall arrest or restraint equipment is required by regulations if it is required by the lift manufacturer. It may also be required if work requires the worker to step up from the work platform, lean out over the guardrails or leave the guarded area. If this occurs, fall protection is required and must consist of an approved anchorage point and a personal fall arrest or restraint system. Departments may require their employees to wear personal fall arrest or restraint equipment for normal work on and within the guarded work platform on scissor or personnel lifts as long as full-body harness/lanyard devices are fixed to attachment points provided and approved by the lift manufacturer. Likewise, individual workers may choose to wear personal fall protection as an extra precaution.

If the work requires the worker to leave the guarded area and go to another area with a fall hazard, the worker must wear a double tie-off Y-lanyard to ensure safe transfer and 100% tie-off. Y-lanyards are designed with two legs so that the worker can navigate obstacles and be tied-off 100% of the time. The concept is that one connector is always connected to a fall protection anchorage, while the other can be attached in a new location to allow the worker to change location and be tied-off.

If fall protection is required on a scissor or personnel lift, a Competent Person must review the fall protection components and Fall Protection Work Plan.

## Aerial lifts

Aerial lifts and boom, telescopic, and articulating lifts can be self-propelled or vehicle-mounted. In addition to guardrails, personal fall arrest or restraint equipment is always required with these lifts. If the work requires the worker to leave the guarded area and go to another area with a fall hazard, the worker wears a double tie-off Y-lanyard to ensure safe transfer and 100% tie-off as discussed above under scissor and personnel lifts. If this is required, a Competent Person must review the fall protection components and Fall Protection Work Plan.

## Procedures for MEWP use

### **Prior to use:**

1. Train all operators and maintenance staff on the specific MEWP in accordance with the manufacturer's operating and maintenance manual and the site-specific instructions.
2. Train all operators and maintenance staff on MEWP safety that includes the hazards of overhead obstructions and steps to take to prevent injury from becoming entangled in these obstructions.

3. Evaluate the ground conditions, traffic, adjacent obstructions and presence of overhead energized electrical lines for actions to take to prevent incidents.
4. Inspect MEWP prior to each use. Follow the manufacturer's manual requirements or adapt the template MEWP Pre-Use Inspection Checklist in [Appendix C](#). Document all required use and maintenance inspections. Do not use if any component fails inspection.
5. Keep operating and maintenance manuals for each MEWP on the equipment.
6. Check the area for adequate clearance from overhead hazards and ensure that surface conditions conform to the manufacturer's requirements.

**During use:**

1. Do not use guardrails to support equipment, materials, or personnel.
2. If personal fall arrest or restraint equipment is required, use the anchor provided and designated by the MEWP manufacturer. Only one person can tie off to the provided anchorage, unless more than one anchor is provided. Anchoring to the guardrails is prohibited.
3. In scissor and personnel lifts, lower work platforms to their base position prior to traveling horizontally to different work positions.
4. Have a ground person present to assist the lift operator if hazardous conditions are encountered, such as vehicular or pedestrian traffic.

[Back to Top](#)



## ROOF ACTIVITIES

---

A fall protection system is required when employees are exposed to fall hazards of 4 feet or more to the ground or lower level. Fall protection must be provided on unguarded roofs when personnel need to access the roof for work-related tasks.

The best fall protection on a roof is a parapet wall or permanent guardrail system at least 42 inches plus or minus three inches high that meets strength requirements.

Passive fall protection controls (such as temporary guardrails) should be considered as the next best protection control, followed by personal fall restraint and then personal fall arrest systems. If these are not possible, administrative controls, including a warning line, safety monitoring and safety watch systems, are to be used (unless they are prohibited by regulations or involve excessive risk).

Roof access must be secured and posted in all buildings and must be restricted to authorized personnel.

### Roof access by contractors

To ensure compliance with regulations, the University requires a roof access permit system when contractors need to access and conduct work on roofs on any UW-owned, leased or managed buildings without being accompanied by UW personnel. See [Appendix E. Roof Access Permit](#) for a Roof Access Permit document. A fillable form Word document is available on the [EH&S website](#). A hazard assessment, including a determination of the appropriate fall protection system(s), is a required element of the roof access permit process.

The Roof Access Permit is completed by:

- (1) Contractor supervisor/manager of contracted employees who will access the roof; **with**
- (2) UW point of contact (e.g., project manager, supervisor, building coordinator)

The UW point of contact for a contractor accessing a roof is responsible for communicating the hazards on the roof and requirements for access. The completed UW Roof Access Permit is reviewed and signed by the UW point of contact and the contractor supervisor/manager. The completed permit is posted at the entrance to the roof during the work.

If there are changes to the scope of work, hazards and/or safeguards identified on an active Roof Access Permit, a new Roof Access Permit must be completed.

### Work on a low slope roof (4:12 or less)

Fall protection requirements on a roof depend on the pitch or slope of the roof, in addition to the distance from the roof edge and the work activity. The 4:12 slope ratio represents a 4-inch vertical rise for every 12 inches of horizontal run.

The conditions and activities performed on the roof dictate when fall protection is required and what type of fall protection is appropriate. Work activities include:

- Roofing work
- Using mechanical equipment in roofing work
- Construction activities other than roofing
- Activities other than construction work

**Fall protection is required on any walking or working surface, including roofs, when there is a fall hazard of 4 feet.** Alternative systems may only be used under specific circumstances and procedures. Alternative systems include a **warning line**, a **safety monitor** and a **safety watch**.

Refer to the guidance document [Using Alternative Fall Protection on Roofs](#) on the [EH&S website](#) for more information on administrative fall protection systems, including warning line, safety monitor and safety watch.

**This guidance applies only to work on a low slope roof (4:12 or less) when traditional fall protection systems cannot be used**, such as a 42-inch parapet wall at the roof edge, guardrails, and personal fall restraint and arrest systems.

- Guardrails or personal fall protection systems are *always* required when working on steep roofs (greater than 4:12).
- This guidance does *not* apply to construction work advancing the roof leading edge or installing the roof deck.
- Fall protection (including alternative systems) is *not* required when work, other than construction activities are infrequent and temporary that occur at least 15 feet from the edge, **and** the employer prohibits worker(s) from going closer than 15 feet from the edge.

Refer to Washington Administrative Codes 296-880-40040, 296-880-40045, and 296-880-40050 for more information.

## Work on a steep slope roof (greater than 4:12)

All work activities on steep slope roofs require personal fall restraint or personal fall arrest systems. Warning line, safety monitor and safety watch systems are **prohibited** on steep slope roofs.

## Skylights, roof hatches and roof openings

Employees must be protected from falling through any hole or opening on a roof, including skylights and roof hatches that are 4 feet or more above the ground or lower level.



[www.bluewater-mfr.com](http://www.bluewater-mfr.com)

**Roof hatch guardrail system**

- Skylights, roof hatches, and roof openings must be protected by installing any of the following:
  - Standard guardrail system along all exposed sides
  - Cover capable of supporting, without failure, at least twice the weight of employees, equipment, and materials that may be imposed on the cover at any one time; temporary covers must be secured over the opening and color coded or marked with the word “hole” or “cover” to warn of the hazard.
  - Barrier that is secured and withstands a load of at least 200 pounds applied in any direction (except upward)
  - Screen that is secured and withstands a load of at least 200 pounds applied horizontally at any point on the near side of the screen
- Roof hatches located within 10 feet of the leading edge must have a standard guardrail system along all exposed sides.
- Roof hatches left open at any distance from the leading edge must be protected on all sides with a guardrail system (except at the entrance to an opening), with the passage through the railing either provided with a swinging gate or so offset that a person cannot walk directly into an opening.
- Roof hatches should be positioned so that a person coming out of the hatch is away from the roof's edge.

**Note:** When a guardrail system, cover, or warning line system (see the guidance document [Using Alternative Fall Protection on Roofs](#)) must be temporarily removed to perform a specific task, an employee must remain at the opening until the guardrail system, cover, or warning line system is replaced. The only duty the employee must perform is to warn persons entering the area of the fall hazard. The employee must be protected from the fall hazard by a personal fall arrest system or personal fall restraint system.

## Mechanical and other equipment maintenance

Heating, ventilating and air conditioning equipment, lighting fixtures, security cameras, microwave dishes, two-way radio antennas, and cell phone towers are some examples of equipment on roofs that may require routine maintenance and servicing.

Servicing and maintenance of HVAC systems may involve accessing HVAC system components at elevated levels above the roof's surface. If mechanical equipment is located within 10 feet of an unguarded roof edge and a worker needs to access the equipment at 30 inches or more above the roof's surface, building codes require that fall protection be provided, such as a guardrail system, or a personal fall restraint or arrest system. Other installations on a roof may require similar fall protection systems to ensure worker safety.

[Back to Top](#)

## SPECIFIC WORK ACTIVITIES

---

### High voltage electrical work

Electrical workers doing high voltage electrical work must wear fall arrest, fall restraint, or work positioning systems when working at elevated locations more than 4 feet above the ground on poles, towers, or similar structures. It is not required when climbing or repositioning.

Note: Unqualified employees (including trainees) are required to use fall protection any time they are more than 4 feet above the ground.

Reference: [WAC 296-45-25510\(12\)](#)

### Tree work

Arborists, or other employees pruning trees or working in trees, must wear fall arrest, fall restraint, or work positioning systems when working at an elevated location more than 4 feet above the ground. It is not required when climbing or repositioning. A climbing rope and safety saddle are generally required when working in trees. See the [LADDERS](#) section and the [MOBILE ELEVATED WORK PLATFORMS](#) section as they apply to tree work.

Washington Administrative Code core safety rules apply to most tree work. Best practices are described in ANSI Z133-2017 Safety Requirements for Arboricultural Operations. Resources include the [National Tree Climbing Guide](#) (Forest Service, U.S. Dept. of Agriculture, 2015).

Reference: [DOSH Directive 20.75 Tree and Shrub Trimming, Pruning and Removal](#)

### Excavations

Employees not directly involved with excavation and trenching activities at the edge of a trench or excavation at 4 feet deep or more must be protected from falling by guardrail systems, fences, barricades, or covers. If walkways are used to permit workers to cross over excavations, guardrails are required on the walkway if the fall would be 4 feet or more to the lower level.

Refer to WAC 296-880-30005 for exemptions and special fall protection requirements for those directly involved in the excavation and trenching activities.

Reference: [WAC 296-155-655\(12\)\(a\)](#)

### Theater and performing arts

At this time, no specific regulations exist for protecting entertainment and performance workers from fall hazards. However, many fall protection regulations described in this document apply to work done by theater and performance workers, and need to be followed to protect both cast and crew. Examples include:

- Fall protection at the edges of stages and elevated platforms
- Use of scaffolds and mobile elevating work platforms in set construction
- Guarding or covering floor and wall openings on stage and over the orchestra pit
- Use of fixed and portable ladders during set construction and takedown
- Fall protection for working at heights with lighting or rigging
- Fall protection for working on tension grid systems
- Catwalk guarding for work on and outside of catwalks

Guardrails and other fall protection measures are not appropriate at the edge of a stage, while administrative controls (e.g., warning lines, training) may be appropriate. Regulatory agencies sometimes exempt performance platforms from fall protection requirements. However, best practices and guidance documents have been developed to assist performing arts departments in developing fall protection programs to ensure the safety of performing artists. Training of all affected persons in theater safety procedures is critical.

**References:**

- ANSI E1.46-2018 *Standard for the Prevention of Falls from Theatrical Stages and Raised Performance Platforms*. (A free [download](#) is available at <http://tsp.esta.org/tsp/documents/downloaddoc.php>)
- University of California, Safety and Loss Prevention, [Performing Arts Safety](#)

[Back to Top](#)

## WINDOW CLEANING AND SUSPENDED MAINTENANCE OPERATIONS

Window cleaning and building facade maintenance workers must pay close attention to all parts of their fall protection system. This includes ensuring that rigging points, lifelines and working lines are in good condition and properly attached. Having adequate and certified anchorage points is critical when working suspended at any height on buildings. If possible, alternatives to suspended work should be used, such as mobile elevating work platforms and scaffolding.

The following information in this section highlights some of the important safety aspects of window cleaning operations for both inside and outside buildings when working above 4 feet, but this section does not cover all of the requirements outlined in [WAC 296-878](#).

All personnel involved in window cleaning or suspended maintenance operations must be responsible for adherence to the guidance in this section as well as any other related sections where applicable.

### Roles and responsibilities

| FALL PROTECTION – WINDOW CLEANING |  |
|-----------------------------------|--|
| Roles                             | Definition/Responsibilities  |
| Qualified Person                  | <p><b>A person is qualified if they have one of the following:</b></p> <ul style="list-style-type: none"> <li>• Extensive knowledge, training, and experience about the subject matter, work, or project</li> <li>• A recognized degree, certificate, or professional standing</li> <li>• Successful demonstration of problem solving skills in connection with the subject, work, or project</li> </ul> |
|                                   | <ul style="list-style-type: none"> <li>• Design, certify, and annually inspect anchorage systems and document results.</li> <li>• Review anchor pull test results.</li> <li>• Review and approve site specific emergency rescue plans.</li> <li>• Train employees and Competent Persons.</li> </ul>  |
| Competent Person                  | <p><b>One who is capable of identifying existing and predictable hazards in the surroundings, or working conditions, which are unsanitary, hazardous, or dangerous to employees, and who has authorization to take prompt corrective measures to eliminate them</b></p>  |
|                                   | <ul style="list-style-type: none"> <li>• Receive training from a Qualified Person(s) or qualified training company specialized in training Competent Persons in fall protection.</li> <li>• Prepare and review Fall Protection Work Plans.</li> </ul>  |

|                 |  |
|-----------------|--|
|                 | <ul style="list-style-type: none"> <li>• Review anchor pull test results.</li> <li>• Inspect anchors before each use.</li> <li>• Identify and monitor locations, activities, and tasks where fall protection is required.</li> <li>• Train employees.</li> </ul>   |
| <b>Employee</b> | <ul style="list-style-type: none"> <li>• Read and understand work platforms and anchorage systems, fall protection controls and systems, procedures, and work plans.</li> <li>• Attend required training on the procedures for safely performing window cleaning and suspended maintenance operations, working at heights and near fall hazards, and proper use of work platforms and fall protection equipment.</li> <li>• Inspect personal fall protection equipment before each use.</li> <li>• Prepare Fall Protection Work Plans.</li> <li>• Report all incidents and unsafe conditions.</li> </ul> |

## Equipment for window cleaning and suspended maintenance operations

According to [WAC 296-878-20005](#), rope descent systems selected for use must:

- Be designed, used and maintained according to ANSI/IWCA 1-14.1-2001 and the manufacturer's instructions
- Have been manufactured and intended to be used for window cleaning

**Note: Equipment that is designed or labeled for recreational use or rescue use only is prohibited for use in window cleaning operations.**

- Ensure that the rope descent system components are compatible and have a minimum tensile strength of 5,000 pounds. This does not apply to the seatboard.
- Ensure the rope descent system has specific use instructions for each component.

## Safe use of rope descent systems

Workers must do the following to safely use rope descent systems ([WAC 296-878-20010](#)):

1. Use extreme care around electrical service, heat sources, and turbulent areas, such as air vents.
2. Connect the seatboard to the descent device with a manual- or auto-locking carabiner.
3. Position yourself in the seatboard before being suspended.
4. Do not reach more than 6 feet in any direction as measured from a centerline straight down from where the suspension rope bears on the building.
5. Do not descend rapidly, swing excessively, or stop suddenly.



6. Ensure there is one other person at the job site who is skilled in using the rope descent system and rescue procedures.
7. Do not exceed a 300 foot height of descent as measured from grade or building setback unless the windows cannot be safely and practicably accessed by other means.
8. Ensure that the site-specific Fall Protection Work Plan addresses the following hazards for descents over 130 feet (as measured from grade or building setback):
  - a. Sudden weather changes, such as wind gusts, micro bursts, or tunneling wind currents
  - b. Inability of the rope descent system to function without using excessive force
  - c. Workers suspended for long periods of time
  - d. Re-rigging and movement of main suspension and safety lines
9. Ensure workers are stabilized when suspended from a rope descent system whenever the descent is higher than 130 feet (as measured from grade or building setback).
10. Do not work when wind speed makes any stabilization equipment ineffective.

**Note: Provisions for stabilizing workers may include:**

- Continuous stabilization, such as mullion tracks
- Intermittent stabilization, such as detent pins or buttons
- Work station stabilization, such as suction cups

## Work platform systems

At the UW, workers use three types of suspended work platforms:

- **Bosun's** (seatboard or boatswain's) **chairs** carry a single person, are descent controlled and cannot be used for ascending.
- **Single person cage**, such as the Spider brand cage, powered by an on-board motor, can descend and ascend a building.
- **Two or more person cage** (wider than 10 feet), such as the Tractel system, powered by on-board motors, can descend and ascend a building.



**Bosun's  
chair**



**Spider single person cage**

Each worker suspended from a bosun's chair or cage platform system must use an independent fall arrest system where the fall arrest anchorage is separate from the chair or cage suspension system anchorage. Each worker must be tied to a different anchor. Workers operating powered platforms must wear and use fall arrest systems. It is UW Facilities' practice to tie off independently, even in the Tractel system, which is certified for tie off to the work platform.

Workers must assemble, inspect, and wear their personal fall arrest equipment before approaching the point of suspension. Workers must be connected **at all times** to the fall arrest system while they are suspended. [WAC 296-878-15025](http://www.wac.gov/wac296-878-15025)

Anchoring systems for suspended window cleaning platforms include:

- Basic roof mounted safety anchors
- Portable outrigger suspension systems secured to roof mounted safety anchors
- Davit suspension systems where permanent davit bases are attached to the building structure



**Tractel cage system**

Before each use, a Competent Person must inspect the work platform system and anchorages, and workers must inspect their personal fall arrest protection systems.

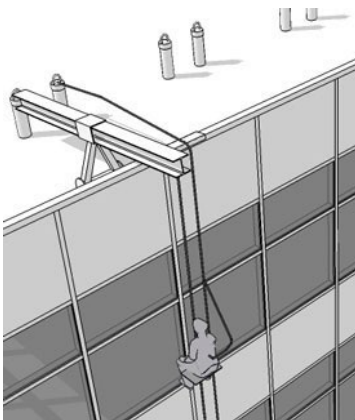

[www.archtoolbox.com](http://www.archtoolbox.com)

**Portable outrigger suspension system with bosun's chair**

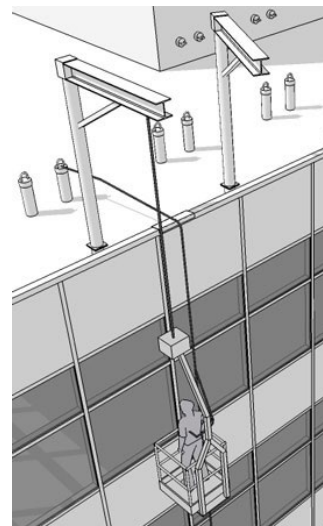

[www.archtoolbox.com](http://www.archtoolbox.com)

**Davit suspension system with single person cage**

## Inspections and certifications

Inspection and certification requirements for suspended maintenance operations (i.e., over the side work) defined by the ANSI/IWCA I-14.1 standard include:

- Manufacturer or designer certifies anchorages before initial use and provides a rated load.
- Qualified Person inspects anchorages annually, or at intervals specified by the manufacturer (not to exceed 12 months); documents annual inspection (see inspection form in [Appendix C](#)).
- Competent Person inspects anchorages before each use.
- Re-certify anchorages during re-roofing, renovating (pertinent to the window cleaning system) or at periods not to exceed 10 years.
- Certification of anchorages must be conducted under the supervision of a registered professional engineer.
- Document and retain records of all certifications and annual inspections.

[Back to Top](#)

## TRAINING

---

Fall protection training is required prior to any employee doing work at heights where fall protection is required. In addition to basic fall protection training, employees who perform the duties of a Competent Person or a Qualified Person must have the necessary experience, knowledge, training, and certification (as needed) to perform their work.

Workers who need training include:

- Employees
- Authorized Persons
- Competent Persons
- Qualified Persons
- Rescuers
- Trainers

### **Training for employees who may be exposed to fall hazards**

A Competent Person must train employees who may be exposed to fall hazards. The training must enable each employee to:

1. Recognize the hazards of falling and the procedures to follow to minimize those hazards.
2. Know at least the following:
  - a. The nature of fall hazards in the work area
  - b. When fall protection is required
  - c. What type(s) of fall protection is required
  - d. Correct procedures for erecting, maintaining, assembling, disassembling, and inspecting fall protection systems to be used
  - e. Use and operation of fall protection systems used
  - f. Limitations of fall protection systems used
  - g. Proper care, maintenance, useful life, and when to remove fall protection systems from service
  - h. The requirements in the UW Fall Protection Program Manual
3. Before performing work requiring fall protection:
  - a. Demonstrate an understanding of the training
  - b. Demonstrate the ability to use fall protection properly
4. Receive retraining, as necessary, because of:
  - a. Workplace changes

- b. Fall protection system changes
- c. Loss of skills

Fall protection training must be documented in writing that each employee has received and understood the required training. The documentation must include:

- Name of each employee
- Date(s) of training
- Subject(s) of training
- Name or signature of Competent Person who conducted the training

### **Training for employees who use fall protection**

Using fall protection requires skills to adequately inspect anchorages and personal fall protection systems, calculate fall clearance, correctly put on a harness, use multiple fall protection systems, and, if applicable, use suspended work systems and descent control.

**Hands-on training is required, and clearly an important part of fall protection training in the classroom and on the job.**

Additional specialized training is needed for workers using suspended systems, such as window cleaning workers.

Additional specialized training is also needed for those using scaffolding and mobile elevating work platforms.

Records must be kept of training classes, including attendance sheets with attendee names, signatures, training dates and name and signature of qualified instructor.

The following class is offered by EH&S:

#### **Fall Protection Training – classroom (2 hours)**

This classroom and hands-on training course will teach employees how to recognize possible fall hazards and falling object hazards, when fall protection methods and plans are needed, and the methods and tools to reduce or eliminate fall hazards. Employees will be taught the difference between fall arrest versus fall restraint protective equipment and when to use each type of protective equipment. Retake the training as a refresher or as directed by a supervisor.

**Intended Audience:** Anyone working more than 10 feet off the ground in a construction or maintenance activity, and employees who use personal fall arrest devices

[Back to Top](#)

# EMERGENCY FALL RESCUE AND ACCIDENT REPORTING

---

## Emergency rescue

A rescue plan must be developed and documented on the Fall Protection Work Plan (see [Appendix B](#)) for all job activities that require a fall restraint or personal fall arrest system while working at heights. The rescue plan must describe how employees will be promptly rescued in the event of a fall or must assure the self-rescue capability of employees. The rescue plan must consider the following rescue types:

### Self-rescue

If possible, the worker(s) should attempt to perform self-rescue following a fall. Self-rescue can include rope descent or climbing back to the level where the fall occurred. Employees must be trained in using self-rescue devices (see [Appendix A Definitions](#) and [WAC 296-880-40035](#)) so they do not panic in the event of a fall. Employees must also be trained in using “suspension trauma relief straps” (see [Appendix F](#)) whether they use self-rescue or not, for suspension trauma relief. The strap is a webbing loop that the person unfurls from the harness in the event of a fall, and provides a means for the person suspended after a fall to avoid suspension trauma. Whatever rescue approach that is used must not risk the safety or health of the worker(s).

### Mobile elevating work platform

- If self-rescue is not possible, determine if using a MEWP is possible.
- The rescuer and the person being rescued must follow fall protection guidance outlined in [MEWP](#) section in this document when performing a rescue with an MEWP.

### External emergency services

- In the event that a worker is unconscious, severely injured, or otherwise incapable of being rescued by on-site staff, contact emergency services immediately by calling 9-1-1 to initiate emergency response (fire department).
- When calling 9-1-1 in Seattle, it should be stated that the “high angle rescue team” is needed. Clearly state your location on the University of Washington campus when calling 9-1-1 from a cellphone.
- Following the notification of emergency services, secure the area and remove all unnecessary personnel.

EH&S will work with individuals as needed to determine the rescue type on their Fall Protection Work Plan and to develop a detailed rescue plan specific to the work area.

Rescue, regardless of the type, should be performed as soon as possible following a fall. Suspension trauma can be a serious health risk following a fall. Communicate to

emergency services personnel whether or not the person in need of fall rescue is conscious, as well as the length of time the person has been suspended.

UW employees are **not** permitted to perform high-angle rescue, which involves a variety of technical rope rescue techniques to rescue injured or otherwise incapacitated persons on slopes of 60 degrees or greater. Victims are hoisted from one level to another using ropes, pulleys, harnesses, belay devices and various hauling implements. Professional responders such as the local fire department will perform this activity during a rescue as needed.

## Accident reporting

All incidents involving a fall must be reported using the [UW Online Accident Reporting System \(OARS\)](#). The person involved or their supervisor submits a report within 24 hours of the incident, or within 8 hours of the incident if a serious injury occurred or the person involved was admitted to a hospital.

[Back to Top](#)

## AUDITS, INSPECTIONS AND CERTIFICATIONS

---

### Inspect prior to use

All components of a fall protection system must be inspected before each use by an Authorized Person or the employee using the equipment, who has been trained by a Competent Person:

- All fall protection equipment including **anchors, body harnesses, lanyards** and connecting hardware. See [Appendix G](#) for fall protection equipment inspection guidelines.
- Equipment used to work at heights must be inspected, such as **mobile elevating work platforms, ladders, and guardrails**.
- **Scaffolds** must be inspected by a Competent Person daily (or before each shift) before use.
- **Suspended systems** must be inspected by a Competent Person before use.

### Inspect every year

Annual Inspections of fall protection equipment must be conducted by a Competent Person or Qualified Person, documented and the records retained:

- Inspection of **body harnesses, lanyards, connecting hardware, snap hooks, and carabiners** at least annually or according to manufacturer's recommendation (See [Appendix G](#) for fall protection equipment inspection guidelines)
- Inspection of **anchors** (detailed information on certification and inspection of anchors is in the [ANCHORS](#) section).

### Fall Protection Program inspections, certifications and audits

The following table lists the inspections, certifications, and audits required by the UW Fall Protection Program, persons to conduct the inspections and frequency of inspections.

Inspection form templates are provided in [Appendix C](#).

The UW Fall Protection Program will be audited annually by EH&S to incorporate updates related to changes to regulations and standards, concerns and needs of employees in the program and areas for improvement.

Feedback on the program should be directed to EH&S Occupational Safety and Health at 206.543.7388 or [ehsdept@uw.edu](mailto:ehsdept@uw.edu).



|  | Equipment/System   | Who inspects                          | Frequency  |
|--|--|---------------------------------------|--|
| Passive Fall Protection Systems                      | Guardrails   | Authorized Person                     | Before each use  |
|  |  | Competent Person                      | Annually   |
|  | Floor/wall openings, covers  | Authorized Person                     | Before each use  |
|  |  | Competent Person                      | Annually   |
| Personal Fall Protection Equipment                   | Fall arrest system harnesses, lanyards, connectors   | Authorized Person                     | Before each use  |
|  |  | Competent person                      | Annually   |
|  | Fall restraint and positioning system harnesses, lanyards, connectors                      | Authorized Person                     | Before each use  |
|  |  | Competent Person                      | Annually   |
|  | Anchorages (temporary, permanent, horizontal and vertical lifelines)                       | Authorized Person                     | Before each use  |
|  |  | Competent Person                      | Before first use, Annually                               |
| Qualified Person to recertify                        |  | At least every 10 years or sooner     |  |
| Ladders and stairways                                | Portable ladders   | Authorized Person                     | Before each use  |
|  |  | Competent Person                      | Annually   |
|  | Fixed ladders  | Authorized Person                     | Before each use  |
|  |  | Competent Person                      | Annually   |
| Stairways  | Competent Person   | Annually                              |  |
| Scaffolds  | Supported  | Competent Person – Scaffolding        | Before first use and before each use daily or each shift |
|  | Mobile   | Competent Person – Scaffolding        | Before first use and before each use daily or each shift |
| Mobile Elevating Work Platforms                      | Scissor and personnel lifts  | Authorized Person                     | Before each use  |
|  |  | Competent Person – MEWP               | Annually   |
|  | Aerial Lifts   | Authorized Person                     | Before each use  |
|  |  | Competent Person – MEWP               | Annually   |
| Window cleaning and suspended maintenance operations | Suspended work platform  | Competent Person                      | Before each use  |
|  |  | Competent Person                      | Annually   |
|  | Anchorages   | Competent Person                      | Before each use  |
|  |  | Qualified Person                      | Annually   |
|  | Personal fall protection systems   | Authorized Person                     | Before each use  |
|  |  | Competent Person                      | Annually   |
| Walking, working surfaces                            | General, walkways, floor/wall openings, stairs/stairways, elevated surfaces, loading docks | Designated and trained employees      | Regularly  |
| Fall Protection Program Audit                        | All  | Qualified or Competent Person in EH&S | At least annually  |

[Back to Top](#)

## RECORDKEEPING

---

The following records must be retained according to UW policy and regulatory record retention requirements:

### Record retention requirements

| <b>Record</b>   | <b>Retention requirement</b>  |
|---|---|
| Training documents  | 7 years   |
| Completed Fall Protection Work Plans  | 6 years or as long as the fall hazard exists at the building or area, whichever is longer |
| Anchor certifications and annual inspections  | For the life of the anchor  |
| Annual inspection checklists of fall protection equipment (harnesses, lanyards, connectors) | 6 years   |
| Annual inspection checklists of portable and fixed ladders                                  | 6 years   |
| Inspections of walking-working surfaces in buildings  | 6 years   |
| Roof access permits   | 1 year  |
| Scaffold pre-use daily inspections  | 1 year  |
| MEWP pre-use inspections  | 1 year  |
| MEWP maintenance records  | 1 year  |

[Back to Top](#)

## CONTRACTORS

---

Contractors working at the UW must:

- Provide to their UW point of contact a copy of their company's Fall Protection Program documents for review prior to performing work.
- Discuss fall protection strategies with all parties involved in the work to ensure that safe work practices and procedures are followed.
- Provide appropriate fall protection systems for employees as required by law, including, but not limited to, guardrail systems and personal fall protection systems as needed or required.
- Complete Job Hazard Analyses and Fall Protection Work Plans in accordance with regulatory requirements, standards and industry best practices.
- Complete a UW Roof Access Permit (see [Appendix E](#)) as required.

[Back to Top](#)

## REFERENCES

| Topic                                  | Regulation/Standard             | Title   |
|--|---------------------------------|---|
| <b>General fall protection</b>         |                                 |   |
|  | <a href="#">WAC 296-24-735</a>  | Walking-working surfaces                              |
|  | <a href="#">WAC 296-880-400</a> | Fall protection system specifications                 |
|  | <a href="#">OSHA 1910.28</a>    | Walking Working Surfaces                              |
|  | ANSI/ASSE Z 359                 | The Fall Protection Code                              |
| <b>Scaffolding</b>                     |                                 |   |
|  | <a href="#">WAC 296-874</a>     | Scaffolds   |
|  | OSHA                            | OSHA Scaffolding <a href="#">e-tool</a>               |
| <b>Mobile Elevating Work Platforms</b> |                                 |   |
|  | <a href="#">WAC 296-869</a>     | Elevating Work Platforms                              |
|  | ANSI A92                        | Vehicle Mounted Elevating and Rotating Work Platforms |
| <b>Window cleaning</b>                 |                                 |   |
|  | <a href="#">WAC 296-878</a>     | Safety standards for window cleaning                  |
|  | ANSI/IWCA I-14                  | Window Cleaning Safety Standard                       |
| <b>Ladders</b>                         |                                 |   |
|  | <a href="#">WAC 296-876</a>     | Ladders, Portable and Fixed                           |
|  | NIOSH                           | <a href="#">Ladder Safety app</a>                     |

[Back to Top](#)

## APPENDICES

### Appendix A. Definitions

| Term                             | Definition  |
|----------------------------------|---|
| <b>100% Tie-off</b>              | A method of transferring from one anchorage or fall arrest system to another, using a “Y-lanyard” or two connecting means. The user remains connected to at least one anchorage/fall arrest system while advancing to the next anchorage point.   |
| <b>Administrative Control</b>    | Employer mandated safe work practices or procedures that are designed to prevent exposure to a fall by signaling or warning an Authorized Person to avoid approaching a fall hazard (designated area, warning line, safety monitor, safety watch)   |
| <b>Anchorage, certified</b>      | An anchorage for fall arrest, positioning, restraint, or rescue that a Qualified Person certifies to be engineered and capable of supporting at least 5,000 pounds of potential fall forces or that meet the criteria for a certified anchorage prescribed in ANSI Z359.0-2007  |
| <b>Anchorage, non-certified</b>  | An anchorage for fall arrest, positioning, restraint, or rescue that a Competent Person has judged to be capable of supporting the predetermined anchorage forces   |
| <b>Aerial lift</b>               | An aerial device mounted on a vehicle such as a truck, trailer, or all-terrain vehicle that can raise and lower a guarded platform or bucket vertically and horizontally to provide safe access to elevated locations   |
| <b>Authorized person</b>         | A person identified by the employer to perform duties at a location where specific hazards exist and is trained and capable of correctly utilizing the fall protection equipment  |
| <b>Calculated fall clearance</b> | The calculated total amount of vertical distance that will be used by a fall arrest system that has fully deployed  |
| <b>Catenary line</b>             | See “Lifeline”  |
| <b>Carabiner</b>                 | See “Snap-hook”   |
| <b>Competent Person</b>          | (Fall protection) An individual knowledgeable of fall protection equipment, including the manufacturer's recommendations and instructions for the proper use, inspection, and maintenance; and who is capable of identifying existing and potential fall hazards; and who has the authority to take prompt corrective action to eliminate those hazards; and who is knowledgeable of the rules contained in this part regarding the |

|                                |   |
|--------------------------------|---|
|                                | installation, use, inspection, and maintenance of fall protection equipment and systems   |
| <b>Contractor</b>              | A person or company that undertakes a contract to provide materials or labor to perform a service or do a job. Contractors can include companies, vendors and suppliers that may do repairs and maintenance work on equipment and facilities, construction, plumbing, electrical, painting, janitorial or other activities. It also includes vendors that maintain, calibrate, test, and repair equipment and instrumentation.  |
| <b>Deceleration device</b>     | Any mechanism which serves to dissipate a substantial amount of energy during a fall arrest, or otherwise limits the energy imposed on a person during fall arrest  |
| <b>Dorsal D-ring</b>           | The mandatory fall arrest connection point on a full-body harness   |
| <b>Energy (shock) absorber</b> | Any mechanism which serves to dissipate a substantial amount of energy during a fall arrest, or otherwise limits the energy imposed on a person during a fall arrest  |
| <b>Fall arrest</b>             | The action or event of stopping a free fall or the instant where the downward free fall has been stopped. A fall arrest system is designed to protect a person in the event of a fall. This will usually consist of a full body harness, shock absorbing lanyard or lifeline and a secure anchor point. Once a person has fallen, these components work together to manage the force of gravity and keep the person from striking obstructions below, including the ground. |
| <b>Fall restraint</b>          | The technique of securing an Authorized Person to an anchorage using a full body harness and a lanyard short enough to prevent the person's center of gravity from reaching the fall hazard   |
| <b>Fixed ladder</b>            | A ladder permanently attached to a structure, building, or equipment. Fixed ladders include individual-rung ladders, but not ship stairs, step bolts, or manhole steps.   |
| <b>Freefall</b>                | The act of falling before a personal fall arrest system begins to apply force to arrest the fall  |
| <b>Freefall distance</b>       | The vertical displacement of the fall arrest attachment point on the employee's body belt or body harness between onset of the fall and just before the system begins to apply force to arrest the fall. This distance excludes deceleration distance and lifeline/lanyard elongation, but includes any deceleration device slide distance or self-retracting lifeline/lanyard extension before they operate and fall arrest forces occur.                                  |
| <b>Full body harness</b>       | Straps that may be secured about the employee in a manner that will distribute the fall arrest forces over at least the thighs, pelvis, waist, chest,   |

|                           |   |
|---------------------------|---|
|                           | and shoulders with means for attaching it to other components of a personal fall arrest system  |
| <b>Guardrail system</b>   | A barrier erected along an unprotected exposed side, edge, or other area of a walking-working surface to prevent a person from falling to a lower level.  |
| <b>Handrail</b>           | A rail used to provide a handhold for support.  |
| <b>Hazard elimination</b> | Changing the task, process, controls, or other means so as to remove the need for an Authorized Person to be exposed to a fall hazard   |
| <b>Hole</b>               | Any gap or void 2 inches or more in its least dimension in a floor, roof, or other walking-working surface  |
| <b>Infrequent</b>         | The task or job is performed only on occasion, when needed (e.g., equipment breakdown), on an occasional basis, or at sporadic or irregular intervals.  |
| <b>Lanyard</b>            | A flexible line of rope, wire rope, or strap that generally has a connector at each end for connecting the full-body harness to an energy (shock) absorber, lifeline, or anchorage  |
| <b>Lanyard, simple</b>    | A lanyard used as a fall restraint device, and does not contain an integrated energy (shock) absorber   |
| <b>Leading edge</b>       | The edge of a floor, roof, or formwork for a floor or other walking-working surface (e.g., a deck), which changes location as additional floor, roof, decking, or formwork sections are placed, formed, or constructed. A leading edge is considered to be an “unprotected side and edge” during periods when it is not actively and continuously under construction.             |
| <b>Lifeline</b>           | Component consisting of a flexible line for connection to an anchorage at one end to hang vertically, or for connection to anchorages at both ends to stretch horizontally, and which serve as a means for connecting other components of a personal fall arrest system to the anchorage<br><br>Note: Horizontal lifelines must be installed and inspected by a Qualified Person. |
| <b>Lower level</b>        | A surface or area to which an employee could fall. Such surfaces or areas include, but are not limited to, ground levels, floors, roofs, ramps, runways, excavations, pits, tanks, materials, water, equipment, and similar surfaces and structures, or portions thereof.   |
| <b>Maintenance</b>        | Making or keeping a structure, fixture, or foundation in proper working condition in a routine, scheduled, or anticipated manner. Maintenance   |

|  |  |
|--|--|
|  | implies keeping equipment working in its existing state; not new installations.  |
| <b>Manhole steps</b>                         | Steps that are individually attached to, or set into, the wall of a manhole structure  |
| <b>Mobile Elevating Work Platform (MEWP)</b> | A mechanical device used to provide temporary access for people or equipment to inaccessible areas, usually at height  |
| <b>Opening</b>                               | A gap or void 30 inches or more high and 18 inches or more wide, in a wall or partition, through which employees can fall to a lower level   |
| <b>Passive fall protection</b>               | Fall protection that does not require the wearing or use of personal fall protection equipment (e.g., guardrails, walls)   |
| <b>Personal fall arrest system</b>           | A system used to slow and stop a person during a fall from an elevated location. It consists of an anchorage, connectors, a full body harness, and may include a lanyard, deceleration device, lifeline, or suitable combinations of these. <b>The use of a body belt for any fall protection is prohibited.</b>                   |
| <b>Platform</b>                              | A walking-working space that is elevated above the surrounding area  |
| <b>Portable ladder</b>                       | A ladder that can be easily moved or carried   |
| <b>Positioning device system</b>             | A full body harness system rigged to allow an employee to be supported on an elevated surface, such as a wall, and work with both hands free while leaning   |
| <b>Qualified person</b>                      | A person who has a recognized degree, certificate, or professional standing, or who by extensive knowledge, training, and experience, has successfully demonstrated the ability to solve or resolve problems related to the subject matter, the work, or the project   |
| <b>Runway</b>                                | An elevated walking-working surface, such as a catwalk, a foot walk along shafting, or an elevated walkway between buildings   |
| <b>Safety monitoring system</b>              | A fall protection system in which a competent person whose only job responsibility is to recognize and warn employees of their proximity to fall hazards when working between the warning line and the unprotected sides and edges, including the leading edge of a low slope roof or other walking-working surface (4:12 or less) |
| <b>Safety watch</b>                          | A type of fall protection system in which a Competent Person is responsible for recognizing and warning one employee of a fall hazard  |



|   |   |
|---|---|
| <b>Self-rescue device</b>               | A piece of equipment designed to allow a person, who is suspended in a personal fall arrest system, to independently rescue themselves after the fall by moving the device up or down until they reach a surface and are no longer suspended  |
| <b>Self-retracting lifeline/lanyard</b> | A self-retracting lifeline/lanyard (SRL) is a specific type of energy (shock) absorbing vertical lifeline used as part of a fall arrest system. The lifeline, like the seat belt in a car, pulls out and retracts easily, but if given a quick tug (or fall) it locks. Once the tension is released, they move freely again. The self-retracting lifeline also incorporates a braking system to spread the sudden impact force over a brief time and distance. This keeps the force transmitted to the body during a fall to a minimum. |
| <b>Snap hook</b>                        | A connector comprised of a hook-shaped member with a normally closed keeper, or similar arrangement, which may be opened to permit the hook to receive an object and, when released, automatically closes to retain the object. Also known as a “carabiner.”  |
| <b>Snug</b>                             | Tight, yet not painful. Capable of accepting the girth of one finger, but not greater.  |
| <b>Stair rail/stair rail system</b>     | A barrier erected along the exposed or open side of stairways to prevent a fall   |
| <b>Stepstool</b>                        | A self-supporting, portable ladder that has flat steps and side rails. This includes only ladders that have a fixed height, do not have a pail shelf, and do not exceed 32 inches in overall height to the top cap, although side rails may extend above the top cap. A stepstool is designed so an employee can climb and stand on all of the steps and the top cap.   |
| <b>Temporary</b>                        | The duration of the task the worker performs is brief or short.   |
| <b>Three (3) points of contact</b>      | To maintain balance and prevent a fall on a ladder, maintain contact with either two hands and one foot, or one hand and two feet.  |
| <b>Unprotected sides and edges</b>      | Any side or edge of a walking-working surface (except at entrances and other points of access) where there is no wall, guardrail system, or stair rail system to protect an employee from falling to a lower level  |
| <b>Walking-working surface</b>          | Any surface, whether horizontal or vertical, on which an employee walks, works, or gains access to a work location. Walking-working surfaces include, but are not limited to, floors, the ground, roofs, ramps, bridges, runways, stairs, dockboards, formwork and concrete reinforcing steel.  |
| <b>Wall opening</b>                     | An opening at least 30 inches high and 18 inches wide in any wall or partition, through which persons may fall  |

|                            |   |
|----------------------------|---|
| <b>Warning line system</b> | A barrier (rope, wire, tape, or chain) erected on a walking-working surface or a low slope roof (4:12 or less), to warn employees that they are approaching an unprotected fall hazard(s)   |
| <b>Y-lanyard</b>           | A lanyard that is manufactured in a “Y” or “double-legged” configuration to provide continuous fall protection when transferring between anchorages. The stem of the “Y” is connected to the user’s full body harness. Each leg of the “Y” is terminated with a snap hook or other connection hardware, and is connected to anchorage points. |

[Back to Top](#)

## Appendix B. Fall Protection Work Plan

The UW Fall Protection Work Plan template shown below includes directions and examples for fall clearance calculations. A fillable form Word document [Fall Protection Work Plan](#) is available on the [EH&S website](#).

Enter information electronically in shaded areas, name Word document file, and save to device. Or print document to enter information manually.

## Fall Protection Work Plan

Fall Protection is required at 4 feet; however, a written plan is required at or above 10 feet

|                          |               |
|--------------------------|---------------|
| Department               | Site Location |
| Job Task                 |               |
| Job Location/Description |               |

|                  |  |
|------------------|--|
| Plan prepared by | Date <a href="#">Click to enter date</a> |
|------------------|--|

- **Workers must review and sign this Fall Protection Work Plan prior to starting work. Workers must understand this plan and be trained in fall protection and the systems and equipment that will be used.**
- **This Fall Protection Work Plan must be posted at the worksite for the duration of work activities.**

| 1. Identify potential fall hazards (check all that apply)  |  |
|--|--|
| <input type="checkbox"/> Mobile elevating work platforms   | <input type="checkbox"/> Stairways                             |
| <input type="checkbox"/> Excavations/trenches  | <input type="checkbox"/> Roof steep slope (greater than 4:12)  |
| <input type="checkbox"/> Floor openings  | <input type="checkbox"/> Roof low slope (4:12 or less)         |
| <input type="checkbox"/> Wall openings   | <input type="checkbox"/> Swing fall                            |
| <input type="checkbox"/> Skylight openings   | <input type="checkbox"/> Hazardous process/equipment           |
| <input type="checkbox"/> Roof openings   | <input type="checkbox"/> Debris/objects falling to lower level |
| <input type="checkbox"/> Elevator shaft  | <input type="checkbox"/> Sharp edges                           |
| <input type="checkbox"/> Ladders (fixed or portable)   | <input type="checkbox"/> Reinforcing steel installation        |
| <input type="checkbox"/> Scaffold  | <input type="checkbox"/> Other:                                |
| 2. Describe the fall hazard(s) details   |  |
|  |  |
| 3. Identify fall protection systems to be used   |  |
| <input type="checkbox"/> Guardrail system  | <input type="checkbox"/> Aerial lift                           |
| <input type="checkbox"/> Covers (holes and openings)   | <input type="checkbox"/> Horizontal lifeline                   |
| <input type="checkbox"/> Appropriate anchors for systems used  | <input type="checkbox"/> Vertical lifeline and rope grab       |
| <input type="checkbox"/> Personal fall arrest system   | <input type="checkbox"/> Warning line                          |
| <input type="checkbox"/> Personal fall restraint system  | <input type="checkbox"/> Safety monitor Name:                  |
| <input type="checkbox"/> Positioning device system   | <input type="checkbox"/> Safety watch Name:                    |
| <input type="checkbox"/> Scaffold with guardrail   | <input type="checkbox"/> Other:                                |
| <input type="checkbox"/> Scissor lift  | <input type="checkbox"/> Other:                                |
| 4. Describe procedures for assembly, maintenance, inspection, disassembly of fall protection system to be used |  |
|  |  |

Enter information electronically in shaded areas, name Word document file, and save to device. Or print document to enter information manually.

|  |                                     |                          |                                       |
|--|-------------------------------------|--------------------------|---------------------------------------|
| <b>5. Describe procedures for handling, storage, securing tools and materials</b>                                    |                                     |                          |                                       |
|  |                                     |                          |                                       |
| <b>6. Identify methods of overhead protection for workers who may be in, or pass through the area below worksite</b> |                                     |                          |                                       |
| <input type="checkbox"/>   | Barricading                         | <input type="checkbox"/> | Toeboards/screens on scaffolds        |
| <input type="checkbox"/>   | Hard hats required                  | <input type="checkbox"/> | Toeboards/covers on floor openings    |
| <input type="checkbox"/>   | Catch net                           | <input type="checkbox"/> | Screens on guardrails                 |
| <input type="checkbox"/>   | Warning signs                       | <input type="checkbox"/> | Secure large tools                    |
| <input type="checkbox"/>   | Tool belts                          | <input type="checkbox"/> | Other:                                |
| <input type="checkbox"/>   | Tool lanyards                       | <input type="checkbox"/> | Other:                                |
| <b>7. Identify method for prompt, safe removal of injured workers      CALL 9-1-1 IF FALL OCCURS</b>                 |                                     |                          |                                       |
| <input type="checkbox"/>   | Written agreement with:             | <input type="checkbox"/> | Self-rescue                           |
| <input type="checkbox"/>   | Site first aid                      | <input type="checkbox"/> | Other employees                       |
| <input type="checkbox"/>   | Elevator/stairs                     | <input type="checkbox"/> | Other:                                |
| <b>8. Identify method used to determine adequacy of anchorage points</b>   |                                     |                          |                                       |
| <input type="checkbox"/>   | Evaluation by professional engineer | <input type="checkbox"/> | Existing engineering/design documents |
| <input type="checkbox"/>   | Manufacturer's data                 | <input type="checkbox"/> | Other:                                |
| <b>9. Describe and identify locations of anchorage points</b>  |                                     |                          |                                       |
|  |                                     |                          |                                       |
| <b>10. Select system components</b>  |                                     |                          |                                       |
| <input type="checkbox"/>   | Full body harness                   | <input type="checkbox"/> | Choker                                |
| <input type="checkbox"/>   | Vertical lifeline                   | <input type="checkbox"/> | Carabiner                             |
| <input type="checkbox"/>   | Horizontal lifeline                 | <input type="checkbox"/> | Rope grab                             |
| <input type="checkbox"/>   | Lanyard                             | <input type="checkbox"/> | Personal shock absorber               |
| <input type="checkbox"/>   | Boatswains chair                    | <input type="checkbox"/> | Beamer                                |
| <input type="checkbox"/>   | Connecting devices (identify)       | <input type="checkbox"/> | Anchorage points (identify)           |
| <input type="checkbox"/>   | Other:                              | <input type="checkbox"/> | Other:                                |
| <b>11. Distance from anchor to ground, lower level or obstruction (see page 4 chart)</b>                             |                                     |                          |                                       |
|  |                                     |                          |                                       |
| <b>12. Calculated minimum fall clearance (see page 4 chart)</b>  |                                     |                          |                                       |
|  |                                     |                          |                                       |

| <b>13. Inspection Checklist</b>   |  |                     |
|---|--|---------------------|
| <input type="checkbox"/>  | Identification Tags  |                     |
| <input type="checkbox"/>  | Horizontal Lifeline Tension is Correct   |                     |
| <input type="checkbox"/>  | Integrity of stitching in Shock Absorber   |                     |
| <input type="checkbox"/>  | Integrity of stitching in Harness/ Lanyard   |                     |
| <input type="checkbox"/>  | Manufacturers assembly/ disassembly instructions   |                     |
| <input type="checkbox"/>  | Locking capability of retractable lanyards assured   |                     |
| <input type="checkbox"/>  | Locking capability of carabiners assured   |                     |
| <input type="checkbox"/>  | Locking capability of snap hooks assured   |                     |
| <input type="checkbox"/>  | Knots and other connection methods do not weaken lifeline  |                     |
| <input type="checkbox"/>  | Lifelines installed and protected from cuts or abrasions   |                     |
| <input type="checkbox"/>  | Rope (wear, fraying, damage, mildew)   |                     |
| <input type="checkbox"/>  | Lanyards (wear, fraying, damage, mildew)   |                     |
| <input type="checkbox"/>  | D-rings have adequate strength, are not cracked or deformed  |                     |
| <input type="checkbox"/>  | Guardrails are sound and of adequate strength  |                     |
| <input type="checkbox"/>  | Devices that are used to connect to horizontal lifelines lock in both directions                         |                     |
| <input type="checkbox"/>  | Anchorage points provide adequate strength and are capable of meeting requirements                       |                     |
| <input type="checkbox"/>  | Warning line meets strength and other requirements   |                     |
| <input type="checkbox"/>  | Safety Monitor is Competent Person, can see workers, is close enough to communicate, has no other duties |                     |
| <input type="checkbox"/>  | Safety Watch is Competent Person, can see worker, is close enough to communicate, has no other duties    |                     |
| <input type="checkbox"/>  | Hole covers are secured, marked and capable of withstanding anticipated weight loads                     |                     |
| <input type="checkbox"/>  | Other  |                     |
| <input type="checkbox"/>  | Other  |                     |
| <b>14. Employee(s) trained to work under this plan</b>                    |  |                     |
| Name (print)  | Signature  | Date                |
|   |  | Click to enter date |
|   |  | Click to enter date |
|   |  | Click to enter date |
|   |  | Click to enter date |
|   |  | Click to enter date |
|   |  | Click to enter date |
|   |  | Click to enter date |
| Name/title of Competent Person who provided training under this plan      |  |                     |
| <b>15. Work plan approval(s)</b>  |  |                     |
| Name of lead worker or supervisor   | Signature  | Date                |
|   |  | Click to enter date |
| Name of Competent Person (If engineered system: Name of Qualified Person) |  |                     |
|   |  | Click to enter date |
| If administrative controls: Name of department manager                    |  |                     |
|   |  | Click to enter date |

Fall clearance is the minimum vertical distance needed between the anchor point and a lower level (this can be the ground or lower obstruction) with a safety factor to prevent the worker from hitting the lower level in a fall.

**What is the distance from the anchor point to the ground or lower level where a worker would fall?**

**If a worker falls, when wearing a fall protection system, what is the minimum fall clearance from the anchor point to the worker's feet including a 3 ft. safety factor?**   (Calculate as shown below.)

The calculated minimum fall clearance of a specific fall protection system may **never** be equal or greater than the distance between the anchor point and the lower level.

| Description   | Distance (ft.) |
|---|----------------|
| Lanyard length or free fall distance for self-retracting lifeline |                |
| Maximum allowable deceleration distance                           | 3 ½ ft.        |
| Workers height  |                |
| Other component if applies  |                |
| Safety factor   | 3              |
| <b>Minimum fall clearance</b> (sum of above)                      |                |

### Calculating Fall Clearance using a Shock-Absorbing Lanyard

Example:

- First, add the length of the shock-absorbing lanyard (6 ft.) to the maximum elongation of the shock absorber during deceleration (3 ½ ft.) to the average height of a worker (6 ft.).
- Then, add a safety factor of 3 ft. to allow for the possibility of an improperly fit harness, a taller than average worker and/or a miscalculation of distance.
- The total, 18 ½ ft. is the suggested safe fall clearance distance for this example.

*NOTE: Should the shock-absorbing lanyard be used in conjunction with a cross-arm anchorage connector or other, the additional length of the anchorage connector must be taken into consideration.*

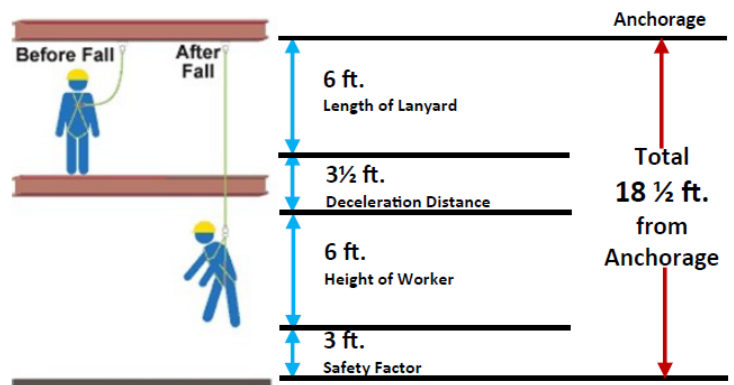

### Calculating Fall Clearance using a Self-Retracting Lifeline

- First, add the maximum free fall distance (2 ft.) with a retractable lifeline to the maximum deceleration distance (3 ½ ft.) to the average height of a worker (6 ft.).
- Then, add a safety factor of 3 ft. to allow for the possibility of an improperly fit harness, a taller than average worker and/or a miscalculation of distance.
- The total, 14 ½ ft. is the suggested safe fall clearance distance for this example.

*NOTE: When using a retractable lifeline, the distance is calculated from the point where the retractable attaches to the back D-ring of the worker's harness.*

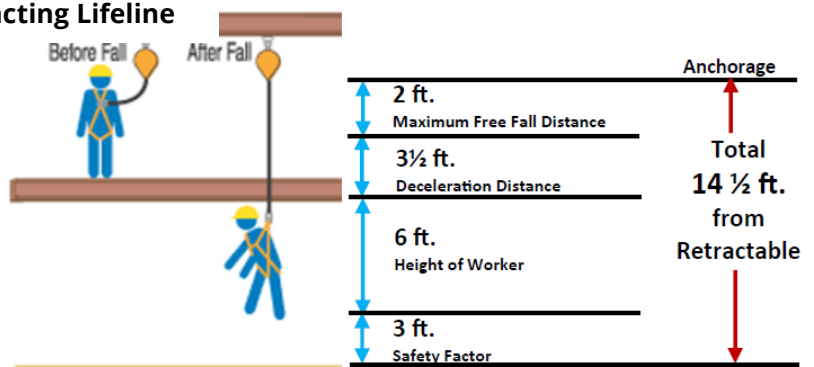

## Appendix C. Inspection checklist templates

| <b>Personal Fall Protection Equipment</b>             | <b>Link to fillable form Word document</b>                         |
|---|--|
| 1. Anchor Annual Inspection                           | <a href="#">Anchor Annual Inspection</a>                           |
| 2. Full-Body Harness Annual Inspection                | <a href="#">Full-Body Harness Annual Inspection</a>                |
| 3. Shock Absorbing Lanyard Annual Inspection          | <a href="#">Shock Absorbing Lanyard Annual Inspection</a>          |
| 4. Self-Retracting Lanyard/Lifeline Annual Inspection | <a href="#">Self-Retracting Lanyard/Lifeline Annual Inspection</a> |
| 5. Snap Hooks/Carabiners Annual Inspection            | <a href="#">Snap Hooks/Carabiners Annual Inspection</a>            |
| <b>Fall Protection Systems</b>                        |  |
| 6. Scaffold Pre-Use Daily Inspection                  | <a href="#">Scaffold Pre-Use Daily Inspection</a>                  |
| 7. Mobile Elevating Work Platform Pre-Use Inspection  | <a href="#">Mobile Elevating Work Platform Pre-Use Inspection</a>  |
| <b>Ladders</b>  |  |
| 8. Portable Ladder Annual Inspection                  | <a href="#">Portable Ladder Annual Inspection</a>                  |
| 9. Fixed Ladder Annual Inspection                     | <a href="#">Fixed Ladder Annual Inspection</a>                     |
| <b>Walking-Working Surfaces</b>                       |  |
| 10. Walking-Working Surfaces Inspection               | <a href="#">Walking-Working Surfaces Inspection</a>                |

[Back to Top](#)



## Anchor Annual Inspection

|  |  |
|--|--|
| Building/Location  | Anchor Type/Material   |
| Date <a href="#">Click to enter date</a>                                     | Anchor I.D.  |
| Inspected By (Competent Person)<br>or (Qualified Person for window cleaning) | Last Certification Date <a href="#">Click to enter date</a><br>(if certified anchor) |

| Labels and Markings                           |   | Pass                     | Fail                     | Comments |
|---|---|--------------------------|--------------------------|----------|
| 1   | Label intact and legible  | <input type="checkbox"/> | <input type="checkbox"/> |          |
| 2   | Appropriate ANSI/OSHA/CSA markings or equivalent ID   | <input type="checkbox"/> | <input type="checkbox"/> |          |
| 3   | Inspections current and up to date  | <input type="checkbox"/> | <input type="checkbox"/> |          |
| 4   | Date of first use   | <input type="checkbox"/> | <input type="checkbox"/> |          |
| <b>Hardware</b>                               |   | <b>Pass</b>              | <b>Fail</b>              |          |
| 6   | Physical Damage: Inspect for cracks, sharp edges, burrs, deformities and locking operation.   | <input type="checkbox"/> | <input type="checkbox"/> |          |
| 7   | Excessive Corrosion: Inspect for corrosion, pitting, nicks that may affect the operation and/or strength.   | <input type="checkbox"/> | <input type="checkbox"/> |          |
| 8   | Fasteners (D-rings, hook gates, connection points, rivets, welds): Inspect for corrosion, tightness, damage and distortion. If welded, inspect weld for corrosion, cracks and damage. | <input type="checkbox"/> | <input type="checkbox"/> |          |
| <b>Webbing (if applicable)</b>                |   | <b>Pass</b>              | <b>Fail</b>              |          |
| 9   | While bending webbing over pipe (simulating a beam wrap), inspect each side for cuts, burns, holes, snags or breaks.  | <input type="checkbox"/> | <input type="checkbox"/> |          |
| 10  | Inspect for swelling, discoloration, cracks, charring from chemical/heat /UV damage. Breaks in stitching.   | <input type="checkbox"/> | <input type="checkbox"/> |          |
| <b>Anchorage Connector</b>                    |   | <b>Pass</b>              | <b>Fail</b>              |          |
| 11  | Termination (stitch, splice or swage)   | <input type="checkbox"/> | <input type="checkbox"/> |          |
| 12  | Inspect for deterioration, excessive wear, corrosion  | <input type="checkbox"/> | <input type="checkbox"/> |          |
| 13  | Cuts, burns, holes  | <input type="checkbox"/> | <input type="checkbox"/> |          |
| 14  | Integrity of welds, rivets  | <input type="checkbox"/> | <input type="checkbox"/> |          |
| 15  | Paint contamination   | <input type="checkbox"/> | <input type="checkbox"/> |          |
| 16  | Stitching, wire condition   | <input type="checkbox"/> | <input type="checkbox"/> |          |
| 17  | Heat corrosion, UV damage   | <input type="checkbox"/> | <input type="checkbox"/> |          |
| 18  | Separation, bird-caging of wire rope  | <input type="checkbox"/> | <input type="checkbox"/> |          |
| <b>Other</b>                                  |   | <b>Pass</b>              | <b>Fail</b>              |          |
|   |   | <input type="checkbox"/> | <input type="checkbox"/> |          |
|   |   | <input type="checkbox"/> | <input type="checkbox"/> |          |
|   |   | <input type="checkbox"/> | <input type="checkbox"/> |          |
|   |   | <input type="checkbox"/> | <input type="checkbox"/> |          |
| <b>Overall Assessment</b>                     |   | <b>Pass</b>              | <b>Fail</b>              |          |
|   |   | <input type="checkbox"/> | <input type="checkbox"/> |          |
| Comments: <a href="#">Click to enter text</a> |   |                          |                          |          |

If anchorage fails, it must be taken out of service and tagged.

Enter information electronically in shaded areas, name Word document file, and save to device. Or print document to enter information manually.

## Full-Body Harness Annual Inspection

|   |  |
|---|--|
| Harness Mfr./Model/Name                                 |  |
| Serial Number   | Lot Number   |
| Date of Manufacture <a href="#">Click to enter date</a> | Date of Purchase <a href="#">Click to enter date</a> |
| Inspected By (Competent Person)                         | Date Inspected <a href="#">Click to enter date</a>   |

| Components                                    |  | Pass                     | Fail                     | Comments |
|---|--|--------------------------|--------------------------|----------|
| <b>Hardware</b>                               |  |                          |                          |          |
| 1   | Inspect D-rings, buckles, keepers and back pads. Inspect for damage, distortion, sharp edges, burrs, cracks, and corrosion | <input type="checkbox"/> | <input type="checkbox"/> |          |
| 2   | Other:   | <input type="checkbox"/> | <input type="checkbox"/> |          |
| <b>Webbing</b>                                |  | <b>Pass</b>              | <b>Fail</b>              |          |
| 3   | Inspect for cuts, burns, tears, abrasions, frays, excessive soiling and discoloration                                      | <input type="checkbox"/> | <input type="checkbox"/> |          |
| 4   | Other:   | <input type="checkbox"/> | <input type="checkbox"/> |          |
| <b>Stitching</b>                              |  | <b>Pass</b>              | <b>Fail</b>              |          |
| 5   | Inspect for pulled or cut stitches   | <input type="checkbox"/> | <input type="checkbox"/> |          |
| 6   | Other:   | <input type="checkbox"/> | <input type="checkbox"/> |          |
| <b>Labels</b>                                 |  | <b>Pass</b>              | <b>Fail</b>              |          |
| 7   | Inspect, making certain all labels are securely held in place and are legible  | <input type="checkbox"/> | <input type="checkbox"/> |          |
| <b>Other</b>                                  |  | <b>Pass</b>              | <b>Fail</b>              |          |
| 8   |  | <input type="checkbox"/> | <input type="checkbox"/> |          |
| <b>Overall Assessment</b>                     |  | <b>Pass</b>              | <b>Fail</b>              |          |
|   |  | <input type="checkbox"/> | <input type="checkbox"/> |          |
| Comments: <a href="#">Click to enter text</a> |  |                          |                          |          |

**If harness fails, it must be tagged and taken out of service.**

## Shock Absorbing Lanyard Annual Inspection

|   |  |
|---|--|
| Lanyard Mfr./Model/Name                                 |  |
| Serial Number   | Lot Number   |
| Date of Manufacture <a href="#">Click to enter date</a> | Date of Purchase <a href="#">Click to enter date</a> |
| Inspected By (Competent Person)                         | Date Inspected <a href="#">Click to enter date</a>   |

| Components                                    |  | Pass                     | Fail                     | Comments |
|---|--|--------------------------|--------------------------|----------|
| <b>Hardware</b>                               |  |                          |                          |          |
| 1   | Inspect snap hooks, carabiners, adjusters, keepers, thimbles, and D-rings.<br>Inspect for damage, distortion, sharp edges, burrs, cracks, corrosion and proper operation | <input type="checkbox"/> | <input type="checkbox"/> |          |
| 2   | Other:   | <input type="checkbox"/> | <input type="checkbox"/> |          |
| <b>Webbing</b>                                |  | <b>Pass</b>              | <b>Fail</b>              |          |
| 3   | Inspect for cuts, burns, tears, abrasions, frays, excessive soiling and discoloration  | <input type="checkbox"/> | <input type="checkbox"/> |          |
| 4   | Other:   | <input type="checkbox"/> | <input type="checkbox"/> |          |
| <b>Stitching</b>                              |  | <b>Pass</b>              | <b>Fail</b>              |          |
| 5   | Inspect for pulled or cut stitches   | <input type="checkbox"/> | <input type="checkbox"/> |          |
| 6   | Other:   | <input type="checkbox"/> | <input type="checkbox"/> |          |
| <b>Synthetic Rope</b>                         |  | <b>Pass</b>              | <b>Fail</b>              |          |
| 7   | Inspect for pulled or cut yarns, burns, abrasions, knots, excessive soiling and discoloration  | <input type="checkbox"/> | <input type="checkbox"/> |          |
| 8   | Other:   | <input type="checkbox"/> | <input type="checkbox"/> |          |
| <b>Energy Absorbing Component</b>             |  |                          |                          |          |
| 9   | Inspect for elongation, tears and excessive soiling  | <input type="checkbox"/> | <input type="checkbox"/> |          |
| 10  | Other:   | <input type="checkbox"/> | <input type="checkbox"/> |          |
| <b>Labels</b>                                 |  | <b>Pass</b>              | <b>Fail</b>              |          |
| 11  | Inspect, making certain all labels are securely held in place and are legible  | <input type="checkbox"/> | <input type="checkbox"/> |          |
| <b>Other</b>                                  |  | <b>Pass</b>              | <b>Fail</b>              |          |
| 12  |  | <input type="checkbox"/> | <input type="checkbox"/> |          |
| <b>Overall Assessment</b>                     |  | <b>Pass</b>              | <b>Fail</b>              |          |
|   |  | <input type="checkbox"/> | <input type="checkbox"/> |          |
| Comments: <a href="#">Click to enter text</a> |  |                          |                          |          |

**If lanyard fails, it must be tagged and taken out of service.**

## Self-Retracting Lanyard/Lifeline Annual Inspection

|   |  |  |  |
|---|--|--|--|
| Lanyard Mfr./Model/Name                                 |  |  |  |
| Serial Number   |  | Lot Number   |  |
| Date of Manufacture <a href="#">Click to enter date</a> |  | Date of Purchase <a href="#">Click to enter date</a> |  |
| Inspected By (Competent Person)                         |  | Date Inspected <a href="#">Click to enter date</a>   |  |

| Components                                    |  | Pass                     | Fail                     | Comments |
|---|--|--------------------------|--------------------------|----------|
| <b>Impact Indicator</b>                       |  |                          |                          |          |
| 1   | Inspect indicator for activation (rupture of red stitching, elongated indicator, etc.)   | <input type="checkbox"/> | <input type="checkbox"/> |          |
| 2   | Other:   | <input type="checkbox"/> | <input type="checkbox"/> |          |
| <b>Screws/Fasteners</b>                       |  | <b>Pass</b>              | <b>Fail</b>              |          |
| 3   | Inspect for damage and make certain all screws and fasteners are tight   | <input type="checkbox"/> | <input type="checkbox"/> |          |
| 4   | Other:   | <input type="checkbox"/> | <input type="checkbox"/> |          |
| <b>Housing</b>                                |  | <b>Pass</b>              | <b>Fail</b>              |          |
| 5   | Inspect for distortion, cracks and other damage. Inspect anchoring loop for distortion or damage.  | <input type="checkbox"/> | <input type="checkbox"/> |          |
| 6   | Other:   | <input type="checkbox"/> | <input type="checkbox"/> |          |
| <b>Lanyard/Lifeline</b>                       |  | <b>Pass</b>              | <b>Fail</b>              |          |
| 7   | Inspect for cuts, burns, tears, abrasion, frays, excessive soiling and discoloration (See impact indicator section.)                         | <input type="checkbox"/> | <input type="checkbox"/> |          |
| 8   | Other:   | <input type="checkbox"/> | <input type="checkbox"/> |          |
| <b>Locking Action</b>                         |  |                          |                          |          |
| 9   | Inspect for proper lockup of brake mechanism   | <input type="checkbox"/> | <input type="checkbox"/> |          |
| 10  | Other:   | <input type="checkbox"/> | <input type="checkbox"/> |          |
| <b>Retraction/Extension</b>                   |  | <b>Pass</b>              | <b>Fail</b>              |          |
| 11  | Inspect spring tension by pulling lanyard out fully and allowing to retract fully (lifeline must be taut with no slack)                      | <input type="checkbox"/> | <input type="checkbox"/> |          |
| <b>Hooks/Carabiners</b>                       |  | <b>Pass</b>              | <b>Fail</b>              |          |
| 12  | Inspect for physical damage (cracks, sharp edges, burrs, deformities), corrosion, proper orientation, markings and proper locking operations | <input type="checkbox"/> | <input type="checkbox"/> |          |
| 13  | Other:   | <input type="checkbox"/> | <input type="checkbox"/> |          |
| <b>Labels</b>                                 |  | <b>Pass</b>              | <b>Fail</b>              |          |
| 14  | Inspect, making certain all labels are securely held in place and are legible  | <input type="checkbox"/> | <input type="checkbox"/> |          |
| <b>Overall Assessment</b>                     |  | <b>Pass</b>              | <b>Fail</b>              |          |
|   |  | <input type="checkbox"/> | <input type="checkbox"/> |          |
| Comments: <a href="#">Click to enter text</a> |  |                          |                          |          |

**If lanyard/lifeline fails, it must be tagged and taken out of service.**

## Snap Hooks/Carabiners Annual Inspection

|   |  |
|---|--|
| Hook/Carabiner Mfr./Model/Name                          |  |
| Serial Number   | Lot Number   |
| Date of Manufacture <a href="#">Click to enter date</a> | Date of Purchase <a href="#">Click to enter date</a> |
| Inspected By (Competent Person)                         | Date Inspected <a href="#">Click to enter date</a>   |

| Components                                    |   | Pass                     | Fail                     | Comments |
|---|---|--------------------------|--------------------------|----------|
| <b>Physical Damage</b>                        |   |                          |                          |          |
| 1   | Inspect for cracks, sharp edges, burrs, deformities and proper locking operations | <input type="checkbox"/> | <input type="checkbox"/> |          |
| 2   | Other:  | <input type="checkbox"/> | <input type="checkbox"/> |          |
| <b>Excessive Corrosion</b>                    |   | <b>Pass</b>              | <b>Fail</b>              |          |
| 3   | Inspect for corrosion, which affects the operation and/or strength                | <input type="checkbox"/> | <input type="checkbox"/> |          |
| 4   | Other:  | <input type="checkbox"/> | <input type="checkbox"/> |          |
| <b>Markings</b>                               |   | <b>Pass</b>              | <b>Fail</b>              |          |
| 5   | Inspect and make certain marking(s) are legible                                   | <input type="checkbox"/> | <input type="checkbox"/> |          |
| 6   | Other:  | <input type="checkbox"/> | <input type="checkbox"/> |          |
| <b>Other</b>                                  |   | <b>Pass</b>              | <b>Fail</b>              |          |
| 7   |   | <input type="checkbox"/> | <input type="checkbox"/> |          |
| <b>Other</b>                                  |   |                          |                          |          |
| 8   |   | <input type="checkbox"/> | <input type="checkbox"/> |          |
| <b>Overall Assessment</b>                     |   | <b>Pass</b>              | <b>Fail</b>              |          |
|   |   | <input type="checkbox"/> | <input type="checkbox"/> |          |
| Comments: <a href="#">Click to enter text</a> |   |                          |                          |          |

**If snap hook/carabiner fails, it must be tagged and taken out of service.**

## Scaffold Pre-Use Daily Inspection

|   |      |               |  |
|---|------|---------------|--|
| Location                                    |      | Project       |  |
| Date <a href="#">Click to enter date</a>    | Time | Scaffold Type |  |
| Inspected By (Competent Person-Scaffolding) |      |               |  |

| Site Conditions                        |   | Yes                      | No                       |
|--|---|--------------------------|--------------------------|
| 1                                      | Has work location been examined before start of work and all appropriate precautions taken? (e.g., checking for overhead objects, falling or tripping hazards, uneven ground) | <input type="checkbox"/> | <input type="checkbox"/> |
| 2                                      | Has the scaffold been set up according to manufacturer's and/or design engineer's instructions?   | <input type="checkbox"/> | <input type="checkbox"/> |
| General Requirements for All Scaffolds |   | Yes                      | No                       |
| 3                                      | Can scaffold components support at least four times their maximum intended load?  | <input type="checkbox"/> | <input type="checkbox"/> |
| 4                                      | Is the maximum load capacity of this scaffold known and communicated to all employees?  | <input type="checkbox"/> | <input type="checkbox"/> |
| 5                                      | Are all platforms fully planked with scaffold grade planks in good condition and no more than 1" gap between planks?  | <input type="checkbox"/> | <input type="checkbox"/> |
| 6                                      | Are platforms at least 18" wide?  | <input type="checkbox"/> | <input type="checkbox"/> |
| 7                                      | Are all platform units cleated, restrained by hooks or equivalent means, or extending over the center line of their supports by at least 6"?                                  | <input type="checkbox"/> | <input type="checkbox"/> |
| 8                                      | Are guardrails (toprail, midrail, toeboard, posts) used on all open sides and ends of scaffolds over 6 ft. high?  | <input type="checkbox"/> | <input type="checkbox"/> |
| 9                                      | Will the guardrails withstand 200 pounds in a downward or outward direction?  | <input type="checkbox"/> | <input type="checkbox"/> |
| 10                                     | Is the front edge of platform less than 14" from face work (if guardrails removed)?   | <input type="checkbox"/> | <input type="checkbox"/> |
| 11                                     | If scaffold components of different manufacturers are used, do they fit together without force and has a competent person determined that they are safe for use?              | <input type="checkbox"/> | <input type="checkbox"/> |
| 12                                     | Are scaffolds, tools, and materials at least 10 ft. away from energized power lines?  | <input type="checkbox"/> | <input type="checkbox"/> |
| 13                                     | Is platform free of clutter, mud, oil, or any tripping hazard?  | <input type="checkbox"/> | <input type="checkbox"/> |
| Supported Scaffolds                    |   | Yes                      | No                       |
| 14                                     | Has the scaffold been constructed to maintain a safety factor of 4:1 height to base width ratio?  | <input type="checkbox"/> | <input type="checkbox"/> |
| 15                                     | If ratio is more than 4:1, are scaffolds secured to a building or structure as required?  | <input type="checkbox"/> | <input type="checkbox"/> |
| 16                                     | Is scaffold plumb, square, and level?   | <input type="checkbox"/> | <input type="checkbox"/> |
| 17                                     | Have diagonal stiff legs and/or guy wires been installed to support the scaffold towers?  | <input type="checkbox"/> | <input type="checkbox"/> |
| 18                                     | Are U-bolts placed over the dead end of the wire, and the saddles placed of the live end of the wire?   | <input type="checkbox"/> | <input type="checkbox"/> |
| 19                                     | Is a guy wire installed at a horizontal member that supports the inner and outer legs?  | <input type="checkbox"/> | <input type="checkbox"/> |
| 20                                     | Are legs, posts, frames and uprights on base plates attached to mudsills (if on dirt)?  | <input type="checkbox"/> | <input type="checkbox"/> |
| 21                                     | Are footings level, sound, rigid, and capable of supporting 4 times the intended load without settling?   | <input type="checkbox"/> | <input type="checkbox"/> |
| 22                                     | Are poles, legs, and uprights plumb and securely braced to prevent swaying or displacement?   | <input type="checkbox"/> | <input type="checkbox"/> |
| 23                                     | Are scaffold components free of any bends, cracks, holes, rust, welding splatter, pits, broken welds, or non-compatible parts?  | <input type="checkbox"/> | <input type="checkbox"/> |
| 24                                     | Unstable objects such as blocks, bricks, buckets, etc. are <b>not</b> used as work platforms or to support scaffolds.   | <input type="checkbox"/> | <input type="checkbox"/> |
| Access                                 |   | Yes                      | No                       |
| 25                                     | Is safe access provided for all scaffold platforms that are more than 2 ft. above or below the point of access?   | <input type="checkbox"/> | <input type="checkbox"/> |
| 26                                     | If ladder used, is it securely attached to the scaffold and extends at least 3 ft. above the platform level?  | <input type="checkbox"/> | <input type="checkbox"/> |

| <b>Stairway-type Ladders</b>                  |  | <b>Yes</b>               | <b>No</b>                |
|---|--|--------------------------|--------------------------|
| 27  | Is the bottom step no more than 24" above the scaffold supporting level and does the ladder extend 36" above the working platform? | <input type="checkbox"/> | <input type="checkbox"/> |
| 28  | Are slip-resistant treads on all steps and landings?   | <input type="checkbox"/> | <input type="checkbox"/> |
| 29  | Are stair rails consisting of a top-rail and a mid-rail provided on each side of each scaffold stairway?                           | <input type="checkbox"/> | <input type="checkbox"/> |
| <b>Use</b>                                    |  | <b>Yes</b>               | <b>No</b>                |
| 31  | Have all workers been properly trained by a qualified person?  | <input type="checkbox"/> | <input type="checkbox"/> |
| 32  | Is scaffolding within rated capacity for loads, materials, workers and weather conditions?   | <input type="checkbox"/> | <input type="checkbox"/> |
| 33  | Has the scaffold been inspected by a competent person as required?   | <input type="checkbox"/> | <input type="checkbox"/> |
| 34  | If any piece of scaffold is defective, has it been removed from service and tagged?  | <input type="checkbox"/> | <input type="checkbox"/> |
| <b>Personal Fall Protection</b>               |  | <b>Yes</b>               | <b>No</b>                |
| 35  | Are personal fall protection systems used where guardrails are not feasible?   | <input type="checkbox"/> | <input type="checkbox"/> |
| <b>Falling Object Protection</b>              |  | <b>Yes</b>               | <b>No</b>                |
| 36  | Have toeboards at least 3.5" high been installed to prevent falling objects?   | <input type="checkbox"/> | <input type="checkbox"/> |
| 37  | Are screens/barriers installed between toeboard and guardrail, if objects taller than toeboards?                                   | <input type="checkbox"/> | <input type="checkbox"/> |
| 38  | Is the area below scaffolding designated hard hat only, barricaded and posted with warning signs?                                  | <input type="checkbox"/> | <input type="checkbox"/> |
| Comments: <a href="#">Click to enter text</a> |  |                          |                          |

## Mobile Elevating Work Platform (MEWP) Pre-use Inspection

|   |              |                          |                   |                          |  |  |  |
|---|--------------|--------------------------|-------------------|--------------------------|--|--|--|
| Department                                    |              |                          |                   | MEWP make/model:         |  |  |  |
| MEWP type:                                    | scissor lift | <input type="checkbox"/> | personnel lift    | <input type="checkbox"/> | MEWP ID:                                 |  |  |
|   | aerial lift  | <input type="checkbox"/> | telescoping lift  | <input type="checkbox"/> | Hour meter reading:                      |  |  |
|   | boom lift    | <input type="checkbox"/> | articulating lift | <input type="checkbox"/> |  |  |  |
| Inspection conducted by (operator/inspector): |              |                          |                   |                          | Date <a href="#">Click to enter date</a> |  |  |

| Power Off Checks                                  | OK                       | No                       | N/A                      | Power On Checks                                    | OK                       | No                       | N/A                      |
|---|--------------------------|--------------------------|--------------------------|--|--------------------------|--------------------------|--------------------------|
| 1. Wheels and tires                               | <input type="checkbox"/> | <input type="checkbox"/> | <input type="checkbox"/> | 22. Unit starts and runs properly                  | <input type="checkbox"/> | <input type="checkbox"/> | <input type="checkbox"/> |
| 2. Lights/strobes                                 | <input type="checkbox"/> | <input type="checkbox"/> | <input type="checkbox"/> | 23. Instruments/gauges                             | <input type="checkbox"/> | <input type="checkbox"/> | <input type="checkbox"/> |
| 3. Mirrors/visibility aids                        | <input type="checkbox"/> | <input type="checkbox"/> | <input type="checkbox"/> | 24. Warning lights/audible alarms                  | <input type="checkbox"/> | <input type="checkbox"/> | <input type="checkbox"/> |
| 4. Engine/engine compartment:                     |                          |                          |                          | 25. Fuel/charge level                              | <input type="checkbox"/> | <input type="checkbox"/> | <input type="checkbox"/> |
| a. Belts/hoses                                    | <input type="checkbox"/> | <input type="checkbox"/> | <input type="checkbox"/> | 26. Horn/audible warning device(s)                 | <input type="checkbox"/> | <input type="checkbox"/> | <input type="checkbox"/> |
| b. Cables/wires                                   | <input type="checkbox"/> | <input type="checkbox"/> | <input type="checkbox"/> | 27. Function controls:                             |                          |                          |                          |
| c. Debris   | <input type="checkbox"/> | <input type="checkbox"/> | <input type="checkbox"/> | a. Boom/jib/lift arms – raise/lower/extend/retract | <input type="checkbox"/> | <input type="checkbox"/> | <input type="checkbox"/> |
| 5. Battery/batteries                              |                          |                          |                          | b. Turret rotate                                   | <input type="checkbox"/> | <input type="checkbox"/> | <input type="checkbox"/> |
| a. Terminals tight                                | <input type="checkbox"/> | <input type="checkbox"/> | <input type="checkbox"/> | c. Drive - forward/reverse                         | <input type="checkbox"/> | <input type="checkbox"/> | <input type="checkbox"/> |
| b. Clean/dry/secure                               | <input type="checkbox"/> | <input type="checkbox"/> | <input type="checkbox"/> | d. Steer – left/right                              | <input type="checkbox"/> | <input type="checkbox"/> | <input type="checkbox"/> |
| 6. Hydraulics:                                    |                          |                          |                          | e. Platform – tilt/rotate/extend                   | <input type="checkbox"/> | <input type="checkbox"/> | <input type="checkbox"/> |
| a. Cylinders/rods                                 | <input type="checkbox"/> | <input type="checkbox"/> | <input type="checkbox"/> | f. Stability enhancing devices                     | <input type="checkbox"/> | <input type="checkbox"/> | <input type="checkbox"/> |
| b. Hoses/lines/fittings                           | <input type="checkbox"/> | <input type="checkbox"/> | <input type="checkbox"/> | g. Function – enable (deadman) devices             | <input type="checkbox"/> | <input type="checkbox"/> | <input type="checkbox"/> |
| 7. Fluids:  |                          |                          |                          | 28. Emergency/auxiliary controls                   | <input type="checkbox"/> | <input type="checkbox"/> | <input type="checkbox"/> |
| a. Engine oil      Level   Leaks                  | <input type="checkbox"/> | <input type="checkbox"/> | <input type="checkbox"/> | 29. Safety interlocks                              | <input type="checkbox"/> | <input type="checkbox"/> | <input type="checkbox"/> |
| b. Engine coolant   Level   Leaks                 | <input type="checkbox"/> | <input type="checkbox"/> | <input type="checkbox"/> | 30. Braking – stops & holds                        | <input type="checkbox"/> | <input type="checkbox"/> | <input type="checkbox"/> |
| c. Hydraulic oil    Level   Leaks                 | <input type="checkbox"/> | <input type="checkbox"/> | <input type="checkbox"/> | 31. Other:   | <input type="checkbox"/> | <input type="checkbox"/> | <input type="checkbox"/> |
| d. Fuel/battery     Level   Leaks                 | <input type="checkbox"/> | <input type="checkbox"/> | <input type="checkbox"/> | <b>General</b>                                     | <b>OK</b>                | <b>No</b>                | <b>N/A</b>               |
| 8. Data/capacity plate                            | <input type="checkbox"/> | <input type="checkbox"/> | <input type="checkbox"/> | 32. Mfr. operating manual stored on MEWP           | <input type="checkbox"/> | <input type="checkbox"/> | <input type="checkbox"/> |
| 9. Counterweight/Counterweight bolt(s)            | <input type="checkbox"/> | <input type="checkbox"/> | <input type="checkbox"/> | 33. Safety decals/warnings/placards                | <input type="checkbox"/> | <input type="checkbox"/> | <input type="checkbox"/> |
| 10. Cover panels                                  | <input type="checkbox"/> | <input type="checkbox"/> | <input type="checkbox"/> | 34. Misc. parts – loose/missing/broken             | <input type="checkbox"/> | <input type="checkbox"/> | <input type="checkbox"/> |
| 11. Boom valley/under platform – leaks/debris     | <input type="checkbox"/> | <input type="checkbox"/> | <input type="checkbox"/> | <b>Work Area Inspection</b>                        | <b>OK</b>                | <b>No</b>                | <b>N/A</b>               |
| 12. Accessory plugs and cables                    | <input type="checkbox"/> | <input type="checkbox"/> | <input type="checkbox"/> | 35. Drop-offs or holes                             | <input type="checkbox"/> | <input type="checkbox"/> | <input type="checkbox"/> |
| 13. Boom/lift arms – general condition/wear       | <input type="checkbox"/> | <input type="checkbox"/> | <input type="checkbox"/> | 36. Bumps and floor/ground obstructions            | <input type="checkbox"/> | <input type="checkbox"/> | <input type="checkbox"/> |
| 14. Power track – lines/hoses                     | <input type="checkbox"/> | <input type="checkbox"/> | <input type="checkbox"/> | 37. Debris   | <input type="checkbox"/> | <input type="checkbox"/> | <input type="checkbox"/> |
| 15. Safety prop functional                        | <input type="checkbox"/> | <input type="checkbox"/> | <input type="checkbox"/> | 38. Overhead obstructions                          | <input type="checkbox"/> | <input type="checkbox"/> | <input type="checkbox"/> |
| 16. Platform-guardrails/toeboard/anchors/gate     | <input type="checkbox"/> | <input type="checkbox"/> | <input type="checkbox"/> | 39. Energized power lines                          | <input type="checkbox"/> | <input type="checkbox"/> | <input type="checkbox"/> |
| 17. Weather-resistant storage compartment/manuals | <input type="checkbox"/> | <input type="checkbox"/> | <input type="checkbox"/> | 40. Hazardous locations                            | <input type="checkbox"/> | <input type="checkbox"/> | <input type="checkbox"/> |
| 18. Control markings visible                      | <input type="checkbox"/> | <input type="checkbox"/> | <input type="checkbox"/> | 41. Ground surface and support conditions          | <input type="checkbox"/> | <input type="checkbox"/> | <input type="checkbox"/> |
| 19. Other:  | <input type="checkbox"/> | <input type="checkbox"/> | <input type="checkbox"/> | 42. Pedestrian/vehicle traffic                     | <input type="checkbox"/> | <input type="checkbox"/> | <input type="checkbox"/> |
| 20. Other:  | <input type="checkbox"/> | <input type="checkbox"/> | <input type="checkbox"/> | 43. Wind and weather conditions                    | <input type="checkbox"/> | <input type="checkbox"/> | <input type="checkbox"/> |
| 21. Other:  | <input type="checkbox"/> | <input type="checkbox"/> | <input type="checkbox"/> | 44. Other possible hazards:                        | <input type="checkbox"/> | <input type="checkbox"/> | <input type="checkbox"/> |

**Report any problems found to supervisor. ALWAYS lock/tag-out unsafe equipment.**

| Item # | Comments/Action Items |
|--------|-----------------------|
|        |                       |
|        |                       |



## Portable Ladder Annual Inspection

|   |                          |                          |                          |                          |  |                 |                  |                          |                          |                          |
|---|--------------------------|--------------------------|--------------------------|--------------------------|--|-----------------|------------------|--------------------------|--------------------------|--------------------------|
| Department                                  |                          |                          |                          |                          | Location of ladder:                      |                 |                  |                          |                          |                          |
| Inspection conducted by (Competent Person): |                          |                          |                          |                          | Date <a href="#">Click to enter date</a> |                 |                  |                          |                          |                          |
| Ladder identification:                      |                          |                          |                          |                          | Ladder length (ft.):                     |                 |                  |                          |                          |                          |
| Ladder type:                                | Stepstool                | Step                     | Straight                 | Extension                | Specialty                                | Specialty type: | Ladder material: | Fiberglass               | Metal                    | Wood                     |
|   | <input type="checkbox"/> | <input type="checkbox"/> | <input type="checkbox"/> | <input type="checkbox"/> | <input type="checkbox"/>                 |                 |                  | <input type="checkbox"/> | <input type="checkbox"/> | <input type="checkbox"/> |

| General for all                |   | Yes                          | No                       |           |
|--------------------------------|---|------------------------------|--------------------------|-----------|
| 1                              | Are the joints between the steps/rungs and side rails tight?  | <input type="checkbox"/>     | <input type="checkbox"/> |           |
| 2                              | Are all hardware and fittings secure (nails, screws, bolts, rivets, hinges, etc.)?                                  | <input type="checkbox"/>     | <input type="checkbox"/> |           |
| 3                              | Are there any loose, cracked, split, dented, rusted, corroded, broken or missing rails, steps or rungs?             | <input type="checkbox"/>     | <input type="checkbox"/> |           |
| 4                              | Are there any sharp surfaces or burrs on rails, steps, rungs or spreaders?  | <input type="checkbox"/>     | <input type="checkbox"/> |           |
| 5                              | Are any steps, rungs, endcaps or shoes damaged or missing?  | <input type="checkbox"/>     | <input type="checkbox"/> |           |
| 6                              | Are the slip-resistant ladder surfaces (rails, steps and rungs) clean and free of dirt, oil and grease?             | <input type="checkbox"/>     | <input type="checkbox"/> |           |
| 7                              | Do all movable parts operate freely without binding or undue play?  | <input type="checkbox"/>     | <input type="checkbox"/> |           |
| 8                              | Is the instructions/warning label missing or not readable?  | <input type="checkbox"/>     | <input type="checkbox"/> |           |
| 9                              | Is the ladder completely stable (no wobbling, resting on an even dry surface)?                                      | <input type="checkbox"/>     | <input type="checkbox"/> |           |
| <b>Step Ladder / Stepstool</b> |   | N/A <input type="checkbox"/> | <b>Yes</b>               | <b>No</b> |
| 10                             | Does step ladder have slip resistant shoes, front and rear side rails, steps, top cap, spreaders or locking hinges? | <input type="checkbox"/>     | <input type="checkbox"/> |           |
| 11                             | Is the spreader loose, bent or broken?  | <input type="checkbox"/>     | <input type="checkbox"/> |           |
| 12                             | Is the spreader or locking device fully functional?   | <input type="checkbox"/>     | <input type="checkbox"/> |           |
| 13                             | Other:  | <input type="checkbox"/>     | <input type="checkbox"/> |           |
| <b>Straight Ladder</b>         |   | N/A <input type="checkbox"/> | <b>Yes</b>               | <b>No</b> |
| 14                             | Does straight ladder have slip resistant shoes, side rails, rungs, endcaps, and instruction/warning label           | <input type="checkbox"/>     | <input type="checkbox"/> |           |
| 15                             | Other:  | <input type="checkbox"/>     | <input type="checkbox"/> |           |
| <b>Extension Ladder</b>        |   | N/A <input type="checkbox"/> | <b>Yes</b>               | <b>No</b> |
| 16                             | Does extension ladder have slip resistant shoes, side rails, rungs, endcaps and instruction/warning label?          | <input type="checkbox"/>     | <input type="checkbox"/> |           |
| 17                             | Does extension ladder have guides or brackets, rung locks, and rope and pulley system for fly section(s)?           | <input type="checkbox"/>     | <input type="checkbox"/> |           |
| 18                             | Are there any loose, broken, missing or defective (don't seat properly) extension locks?                            | <input type="checkbox"/>     | <input type="checkbox"/> |           |
| 19                             | Is the rope for the pulley system frayed or worn?   | <input type="checkbox"/>     | <input type="checkbox"/> |           |
| 20                             | Other:  | <input type="checkbox"/>     | <input type="checkbox"/> |           |
| <b>Specialty Ladder</b>        |   | N/A <input type="checkbox"/> | <b>Yes</b>               | <b>No</b> |
| 21                             | Are any parts of platform or guard rails missing, loose, bent or broken?  | <input type="checkbox"/>     | <input type="checkbox"/> |           |
| 22                             | Are any casters loose, have rust or corrosion?  | <input type="checkbox"/>     | <input type="checkbox"/> |           |
| 23                             | Are any fasteners, locks or hinges loose, bent, broken or missing?  | <input type="checkbox"/>     | <input type="checkbox"/> |           |

| Item # | Comments/Action Items (e.g., "tagged out as damaged and removed from use") |
|--------|--|
|        |  |
|        |  |
|        |  |
|        |  |
|        |  |

|                          |                             |
|--------------------------|-----------------------------|
| <input type="checkbox"/> | Ladder is in good condition |
|--------------------------|-----------------------------|

## Fixed Ladder Annual Inspection

|   |   |
|---|---|
| Department:                                 | Building:                                 |
| Location of ladder:                         |   |
| Inspection conducted by (Competent Person): | Date: <a href="#">Click to enter date</a> |
| Ladder description/identification:          | Ladder length (ft.):                      |

This checklist does not apply to:

1. Fixed ladder rungs and steps on telecommunication towers and elevator shafts
2. Individual rung ladders
3. Mobile ladders
4. Step bolts and manhole steps

All items are WA or federal regulations except where noted ANSI 14.3 standard (2008)

| General |  | Yes                      | No                       |
|---------|--|--------------------------|--------------------------|
| 1       | Are ladder rungs spaced 10 to 14" apart, measured between the center line of the rungs and uniform through the length of the ladder?   | <input type="checkbox"/> | <input type="checkbox"/> |
| 2       | Are rungs or cleats at least 16" wide?   | <input type="checkbox"/> | <input type="checkbox"/> |
| 3       | Is the clearance between the steps or rungs or grab bars and the structure at least 7 inches?  | <input type="checkbox"/> | <input type="checkbox"/> |
| 4       | Are grab bars protruding on the climbing side beyond the rungs of the ladder?  | <input type="checkbox"/> | <input type="checkbox"/> |
| 5       | Do the side rails and grab bars extend 42" above the top access level or landing platform?   | <input type="checkbox"/> | <input type="checkbox"/> |
| 6       | For through ladders, are rungs omitted from extensions, and side rails flared to provide 24 to 30" of clearance?   | <input type="checkbox"/> | <input type="checkbox"/> |
| 7       | If a ladder safety system is installed, is the clearance between side rails of the extension less than 36 inches?  | <input type="checkbox"/> | <input type="checkbox"/> |
| 8       | Is the size (cross section) of grab bars and rungs the same?   | <input type="checkbox"/> | <input type="checkbox"/> |
| 9       | Is the top rung of the ladder level with the top of access/egress level or landing platform? [ANSI A14.3 (2008)]   | <input type="checkbox"/> | <input type="checkbox"/> |
| 10      | Is the first rung of the ladder within 14" of the ground? [ANSI A14.3 (2008)]  | <input type="checkbox"/> | <input type="checkbox"/> |
| 11      | When ladder terminates at a hatch does the cover open with sufficient clearance to provide easy access to or from the ladder?  | <input type="checkbox"/> | <input type="checkbox"/> |
| 12      | For through ladders, is the step-across distance from the centerline of rungs between 7 and 12" to the nearest edge of the structure, building or equipment?   | <input type="checkbox"/> | <input type="checkbox"/> |
| 13      | For ladders without a cage or well, is the clearance width on each side of the ladder centerline to the nearest permanent object at least 15 inches?   | <input type="checkbox"/> | <input type="checkbox"/> |
| 14      | For ladders without a cage or well, is the minimum distance from the centerline of the rungs to the nearest object on the climbing side at least 30 inches?<br>When unavoidable obstructions are encountered, the minimum clearance at the obstruction may be reduced to 24", provided deflector plates are installed. | <input type="checkbox"/> | <input type="checkbox"/> |
| 15      | Does the ladder meet applicable WA regulations and ANSI standards?   | <input type="checkbox"/> | <input type="checkbox"/> |
| 16      | Is the ladder in good working condition (no defects such as loose rungs or steps or side rails, cracks, corrosion, or other deterioration that may impact safety)?   | <input type="checkbox"/> | <input type="checkbox"/> |
|         | Are rungs free of excess dirt, grease, oil or slippery material?   | <input type="checkbox"/> | <input type="checkbox"/> |
| 17      | Other:   | <input type="checkbox"/> | <input type="checkbox"/> |

| <b>Existing fixed ladders with cages</b><br><b>Note: Inspection of cage is required until such time the cage is removed and the ladder is equipped with a ladder safety system or fall arrest system.</b> |  | <b>Yes</b>               | <b>No</b>                |
|---|--|--------------------------|--------------------------|
| 18  | Do side rails that might be used as a climbing aid provide adequate gripping surface without sharp edges?  | <input type="checkbox"/> | <input type="checkbox"/> |
| 19  | Does the bottom of the ladder cage start 7 to 8 ft. above the base of the ladder?  | <input type="checkbox"/> | <input type="checkbox"/> |
| 20  | Is the bottom of the cage flared at least 4 inches?  | <input type="checkbox"/> | <input type="checkbox"/> |
| 21  | Is the clearance from the centerline of the ladder rung to the back of the cage between 27 and 28" and the cage is at least 27" wide?  | <input type="checkbox"/> | <input type="checkbox"/> |
| 22  | Are the vertical bars of the cage located at a maximum spacing of 40 degrees around the circumference of the cage giving a maximum spacing of approximately 9.5" center to center? | <input type="checkbox"/> | <input type="checkbox"/> |
| 23  | Other:   | <input type="checkbox"/> | <input type="checkbox"/> |
| <b>Landing platforms</b><br><b>(required for ladders over 30 ft. in length, or 20 ft. in length for ladders with no cages)</b>  |  | <b>Yes</b>               | <b>No</b>                |
| 24  | Is the landing platform at least 24 by 30 inches?  | <input type="checkbox"/> | <input type="checkbox"/> |
| 25  | Is the landing platform equipped with standard railings and toeboards?   | <input type="checkbox"/> | <input type="checkbox"/> |
| 26  | Is one rung of a ladder section located at the level of the landing laterally served by the ladder?  | <input type="checkbox"/> | <input type="checkbox"/> |
| <b>Ladder safety system</b><br><b>(required for ladders over 20 ft. in length, in lieu of cages)</b>  |  | <b>Yes</b>               | <b>No</b>                |
| 27  | Is a properly designed ladder fall arrest safety system installed on ladders greater than 20 ft. in length where no cage is provided?  | <input type="checkbox"/> | <input type="checkbox"/> |

| <b>Item #</b> | <b>Comments/Action Items (tagged out as damaged or prohibited from use)</b> |
|---------------|---|
|               |   |
|               |   |
|               |   |
|               |   |
|               |   |

Ladder is in good condition

## Walking-Working Surfaces Inspection

|                          |  |
|--------------------------|--|
| Department               | Location                                 |
| Inspection conducted by: | Date <a href="#">Click to enter date</a> |

Note: If a correction or repair involves the structural integrity of the surface, a Qualified Person must perform or supervise the correction or repair.

| General Work Environment |  | Yes                          | No                       |    |
|--------------------------|--|------------------------------|--------------------------|----|
| 1                        | Is a documented, functioning housekeeping program in place?  | <input type="checkbox"/>     | <input type="checkbox"/> |    |
| 2                        | Are all worksites clean, sanitary and orderly?   | <input type="checkbox"/>     | <input type="checkbox"/> |    |
| 3                        | Are work surfaces kept dry and appropriate means taken to assure the surfaces are slip-resistant?  | <input type="checkbox"/>     | <input type="checkbox"/> |    |
| 4                        | Are all spilled hazardous materials or liquids, including blood and other potentially infectious materials, cleaned up immediately and according to proper procedures?           | <input type="checkbox"/>     | <input type="checkbox"/> |    |
| 5                        | Is combustible scrap, debris and waste stored safely and removed from the worksite promptly?   | <input type="checkbox"/>     | <input type="checkbox"/> |    |
| 6                        | Are accumulations of combustible dust routinely removed from elevated surfaces, including the overhead structure of buildings, etc.?   | <input type="checkbox"/>     | <input type="checkbox"/> |    |
| 7                        | Is combustible dust cleaned up with a vacuum system to prevent airborne dust particles in the environment?   | <input type="checkbox"/>     | <input type="checkbox"/> |    |
| 8                        | Is metallic or conductive dust prevented from entering or accumulating on or near electrical enclosures or equipment?  | <input type="checkbox"/>     | <input type="checkbox"/> |    |
| 9                        | Are covered metal waste cans used for oily or paint-soaked waste?  | <input type="checkbox"/>     | <input type="checkbox"/> |    |
| 10                       | Is cleaning equipment and chemicals stored properly?   | <input type="checkbox"/>     | <input type="checkbox"/> |    |
| 11                       | Are walkways and stairways properly illuminated?   | <input type="checkbox"/>     | <input type="checkbox"/> |    |
| Walkways                 |  | N/A <input type="checkbox"/> | Yes                      | No |
| 12                       | Are aisles and walkways kept clear and marked as appropriate?  | <input type="checkbox"/>     | <input type="checkbox"/> |    |
| 13                       | Are wet surfaces covered with non-slip materials?  | <input type="checkbox"/>     | <input type="checkbox"/> |    |
| 14                       | Are holes in the floor, sidewalk, or other walking surface repaired properly, covered, or otherwise made safe?   | <input type="checkbox"/>     | <input type="checkbox"/> |    |
| 15                       | Is there safe clearance for walking in aisles where motorized or mechanical handling equipment is operating?   | <input type="checkbox"/>     | <input type="checkbox"/> |    |
| 16                       | Are materials or equipment stored in such a way that sharp projections will not interfere with the walkway?  | <input type="checkbox"/>     | <input type="checkbox"/> |    |
| 17                       | Are spilled materials cleaned up immediately?  | <input type="checkbox"/>     | <input type="checkbox"/> |    |
| 18                       | Are changes of direction or elevations readily identifiable?   | <input type="checkbox"/>     | <input type="checkbox"/> |    |
| 19                       | Are aisles or walkways that pass near moving or operating machinery, welding operations, or similar operations arranged so employees will not be subjected to potential hazards? | <input type="checkbox"/>     | <input type="checkbox"/> |    |
| 20                       | Is adequate headroom provided for the entire length of any aisle or walkway?   | <input type="checkbox"/>     | <input type="checkbox"/> |    |
| 21                       | Are standard guardrails provided wherever aisle or walkway surfaces are elevated more than 30 inches above any adjacent floor or the ground?                                     | <input type="checkbox"/>     | <input type="checkbox"/> |    |
| 22                       | Are bridges provided over conveyors and similar hazards?   | <input type="checkbox"/>     | <input type="checkbox"/> |    |
| 23                       | Other:   | <input type="checkbox"/>     | <input type="checkbox"/> |    |
| Floor and Wall Openings  |  | N/A <input type="checkbox"/> | Yes                      | No |
| 24                       | Are floor openings guarded by a cover, a guardrail, or equivalent on all sides (except at stairways or ladder entrances)?  | <input type="checkbox"/>     | <input type="checkbox"/> |    |
| 25                       | Are toeboards (minimum vertical 3.5" height) installed around the edges of permanent floor openings where persons may pass below the opening?                                    | <input type="checkbox"/>     | <input type="checkbox"/> |    |
| 26                       | Are skylight screens able to withstand a load of at least 200 pounds?  | <input type="checkbox"/>     | <input type="checkbox"/> |    |
| 27                       | Is the glass in windows, doors, glass walls, etc., that is subject to possible human impact of sufficient thickness and type for the condition of use?                           | <input type="checkbox"/>     | <input type="checkbox"/> |    |
| 28                       | Are grates or similar type covers over floor openings, such as floor drains, designed to allow unimpeded foot traffic or rolling equipment?                                      | <input type="checkbox"/>     | <input type="checkbox"/> |    |
| 29                       | Are unused portions of service pits and pits not in use either covered or protected by guardrails or equivalent?   | <input type="checkbox"/>     | <input type="checkbox"/> |    |

|                             |   |                                     |                          |
|-----------------------------|---|-------------------------------------|--------------------------|
| 30                          | Are manhole covers, trench covers and similar covers, and their supports designed to carry a truck rear axle load of at least 20,000 pounds when located in roadways and subject to vehicle traffic?  | <input type="checkbox"/>            | <input type="checkbox"/> |
| 31                          | Are floor or wall openings in fire-resistant construction provided with doors or covers compatible with the fire rating of the structure and provided with a self-closing feature when appropriate?   | <input type="checkbox"/>            | <input type="checkbox"/> |
| 32                          | Other:  | <input type="checkbox"/>            | <input type="checkbox"/> |
| <b>Stairs and Stairways</b> |   | <b>N/A</b> <input type="checkbox"/> | <b>Yes</b> <b>No</b>     |
| 33                          | Are handrails, stair rail systems, or guard rail systems installed on all stairways having four or more risers?   | <input type="checkbox"/>            | <input type="checkbox"/> |
| 34                          | Are all stairways at least 22 inches wide?  | <input type="checkbox"/>            | <input type="checkbox"/> |
| 35                          | Do stairs have at least 6 feet, 8 inches of overhead clearance?   | <input type="checkbox"/>            | <input type="checkbox"/> |
| 36                          | Do stairs angle no more than 50 degrees and no less than 30 degrees?  | <input type="checkbox"/>            | <input type="checkbox"/> |
| 37                          | Are risers on stair steps uniform in size, with no riser higher than 9.5 inches?  | <input type="checkbox"/>            | <input type="checkbox"/> |
| 38                          | Are stair treads uniform in size, with tread depth no less than 9.5 inches?   | <input type="checkbox"/>            | <input type="checkbox"/> |
| 39                          | Are steps slip-resistant?   | <input type="checkbox"/>            | <input type="checkbox"/> |
| 40                          | Are stairway handrails located between 30 inches and 38 inches above the leading edge of stair treads?  | <input type="checkbox"/>            | <input type="checkbox"/> |
| 41                          | Is the distance of stair rail systems above the leading edge of stair treads at least 30 inches (if installed before 10/1/20) or 42 inches (if installed after 10/1/20)?  | <input type="checkbox"/>            | <input type="checkbox"/> |
| 42                          | Do stairway handrails have at least 2.25 inches of clearance between the handrails and the wall or surface they are mounted on?   | <input type="checkbox"/>            | <input type="checkbox"/> |
| 43                          | Where doors or gates open directly onto a stairway, is a platform provided so the swing of the door does not reduce the width of the platform to less than 20 inches (if installed before 10/1/20) or 22 inches (if installed after 10/1/20)? | <input type="checkbox"/>            | <input type="checkbox"/> |
| 44                          | Are stairway handrails capable of withstanding a load of 200 pounds, applied in any direction?  | <input type="checkbox"/>            | <input type="checkbox"/> |
| 45                          | Where stairs or stairways exit directly into any area where vehicles may be operated, are adequate barriers and warnings provided to prevent employees from stepping into traffic?  | <input type="checkbox"/>            | <input type="checkbox"/> |
| 46                          | Other:  | <input type="checkbox"/>            | <input type="checkbox"/> |
| <b>Elevated Surfaces</b>    |   | <b>N/A</b> <input type="checkbox"/> | <b>Yes</b> <b>No</b>     |
| 47                          | Are signs posted, when appropriate, showing the elevated surface load capacity?   | <input type="checkbox"/>            | <input type="checkbox"/> |
| 48                          | Are surfaces that are elevated more than 30 inches provided with standard guardrails?   | <input type="checkbox"/>            | <input type="checkbox"/> |
| 49                          | Are all elevated surfaces beneath which people or machinery could be exposed to falling objects provided with toeboards (minimum 3.5" vertical height)?   | <input type="checkbox"/>            | <input type="checkbox"/> |
| 50                          | Is a permanent means of access and egress provided to elevated storage and work surfaces?   | <input type="checkbox"/>            | <input type="checkbox"/> |
| 51                          | Is required headroom provided where necessary?  | <input type="checkbox"/>            | <input type="checkbox"/> |
| 52                          | Is material on elevated surfaces piled, stacked, or racked in a manner to prevent it from tipping, falling, collapsing, rolling, or spreading?  | <input type="checkbox"/>            | <input type="checkbox"/> |
| 53                          | Other:  | <input type="checkbox"/>            | <input type="checkbox"/> |
| <b>Loading Docks</b>        |   | <b>N/A</b> <input type="checkbox"/> | <b>Yes</b> <b>No</b>     |
| 54                          | Are dock boards or bridge plates used when transferring materials between docks and trucks?   | <input type="checkbox"/>            | <input type="checkbox"/> |
| 55                          | If loading dock height is 48 inches or higher, are there fall protection measures in place?   | <input type="checkbox"/>            | <input type="checkbox"/> |
| 56                          | If activities bring high traffic close to a hazard (e.g., an edge), are the floors marked or guards in place?   | <input type="checkbox"/>            | <input type="checkbox"/> |
| 57                          | Has the dock area been periodically cleaned to remove accumulated debris?   | <input type="checkbox"/>            | <input type="checkbox"/> |
| 58                          | If present, is emergency equipment blocked or damaged (e.g., fire extinguisher)?  | <input type="checkbox"/>            | <input type="checkbox"/> |
| 59                          | Are dock plates and boards designed for the weight of the anticipated loads, and are lift trucks being used properly and in good repair?  | <input type="checkbox"/>            | <input type="checkbox"/> |
| 60                          | Other:  | <input type="checkbox"/>            | <input type="checkbox"/> |
| <b>Item #</b>               | <b>Comments/Action Items</b>  |                                     |                          |
|                             |   |                                     |                          |

## Appendix D. Handrails and stair rail systems

**Handrails** are rails that provide a handhold for support.

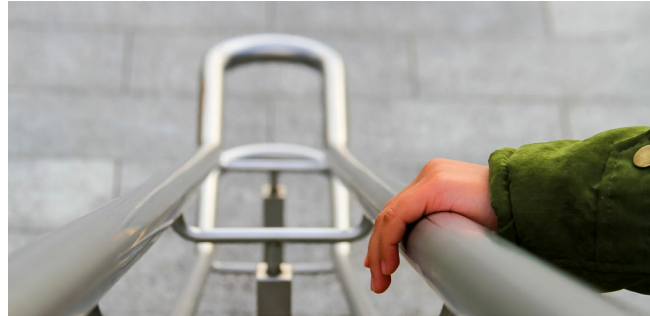

[www.osha.oregon.gov](http://www.osha.oregon.gov)

### Basic requirements for handrails

|                          |   |
|--------------------------|---|
| <b>Height</b>            | Minimum handrail height is 30 inches; maximum height is 38 inches; height is measured from the leading edge of the stair tread to the top surface of the handrail.                    |
| <b>Finger clearance</b>  | Minimum clearance between a handrail and any other object is 2.25 inches  |
| <b>Surface</b>           | Handrail surfaces must be smooth.   |
| <b>Handholds</b>         | Handrails must be designed so that they can be grasped firmly.  |
| <b>End of a handrail</b> | The end of a handrail must not present a projection hazard.   |
| <b>Strength</b>          | Handrails must withstand, without failure, a force of at least 200 pounds applied in any downward or outward direction within two inches of any point along the top edge of the rail. |

Each flight of stairs having at least four risers and three treads must have:

- At least one handrail
- Stairs wider than 44 inches must have a handrail on each side.
- Stairs wider than 88 inches must also have a handrail down the middle of the stairway.
- There must be a stair rail at each open side.

A **stair rail system** — or stair rail — is a barrier erected along the exposed or open side of stairways to prevent a fall.



www.osha.oregon.gov

### Basic requirements for stair rail systems

|   |   |
|---|---|
| <b>Height</b>   | The minimum height of stair rail systems installed before October 1, 2020, is 30 inches, measured from the leading edge of the stair tread to the top surface of the top rail. The minimum height of stair rail systems installed after October 1, 2020, is 42 inches, measured from the leading edge of the stair tread to the top surface of the top rail.  |
| <b>Surface</b>  | Stair rails must be smooth.   |
| <b>Openings</b>   | Any opening in a stair rail system must not exceed 19 inches.   |
| <b>End of stair rail</b>  | The end of a stair rail must not present a projection hazard.   |
| <b>Strength</b>   | The top rails of stair rail systems must withstand, without failure, a force of at least 200 pounds applied in any downward or outward direction within two inches of any point along the top edge of the rail.   |
| <b>Can the top rail of a stair rail system serve as a handrail?</b> | For stair rail systems installed before October 1, 2020, the top rail may serve as a handrail only when the top rail is between 36 inches and 38 inches high (measured from the leading edge of the stair tread to the top surface of the top rail), and the top rail meets all other handrail requirements.<br><br>For stair rail systems installed after October 1, 2020, the top rail and handrail must be separate. The top rail must be at least 42 inches high, and the handrail must be 30 inches to 38 inches high. |

## Handrail Measurement

Handrails must be not less than 30 inches and not more than 38 inches, as measured from the leading edge of the stair tread to the top surface of the handrail.

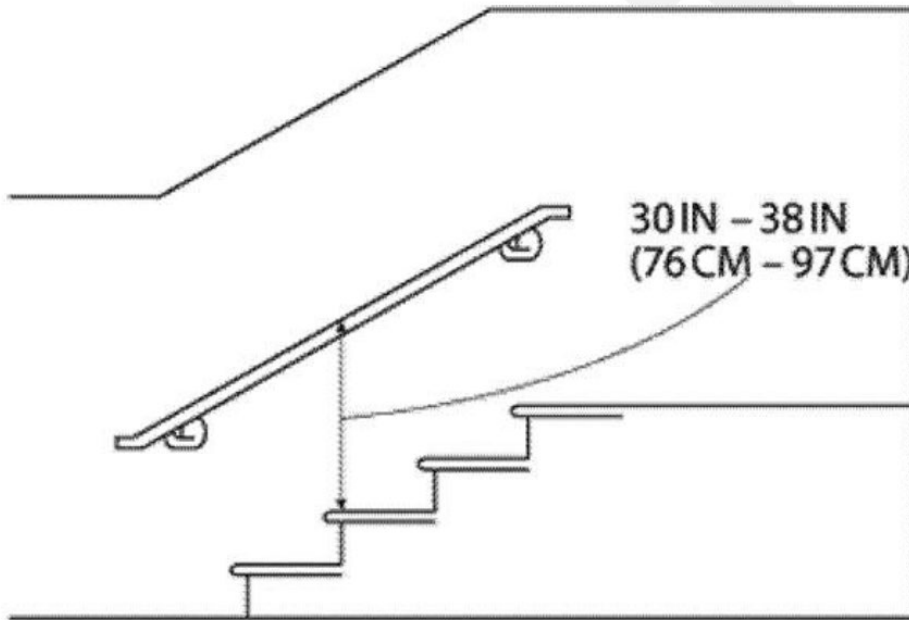



## Combination handrail and stair rail system measurements

*System installed before October 1, 2020*

The top rail of a stair rail system installed before October 1, 2020, may serve as a handrail only when the height of the stair rail system is not less than 36 inches and not more than 38 inches as measured at the leading edge of the stair tread to the top surface of the top rail.

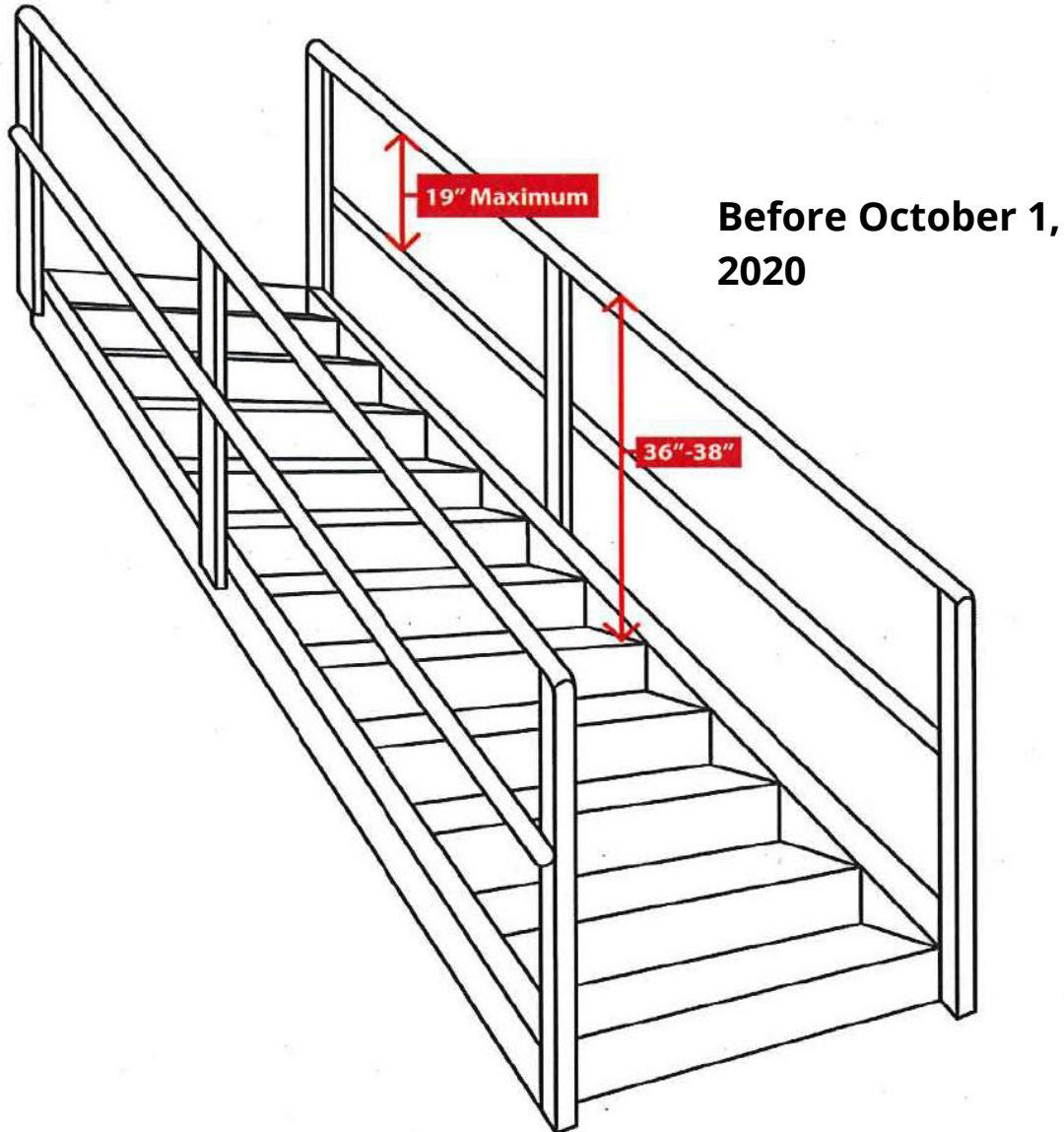

*System installed after October 1, 2020*

The height of stair rail systems installed on or after October 1, 2020 is not less than 42 inches from the leading edge of the stair tread to the top surface of the top rail. Hand rails and stair rails constructed after October 1, 2020 must be separate.

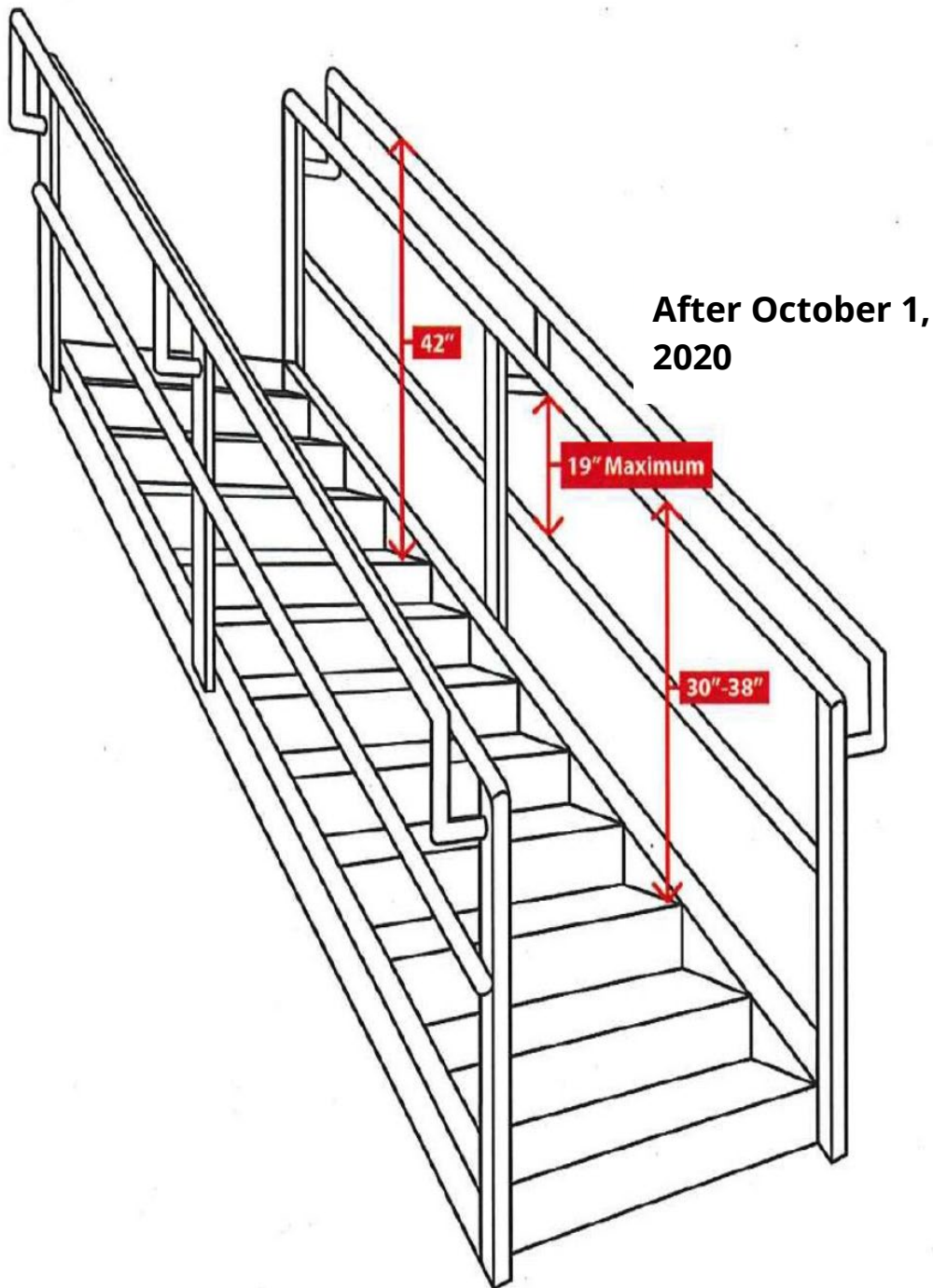

## Standard stairs measurements

Standard stairs must have:

- a. Maximum riser height of 9.5 inches
- b. Minimum tread depth of 9.5 inches
- c. Minimum width of 22 inches between vertical barriers

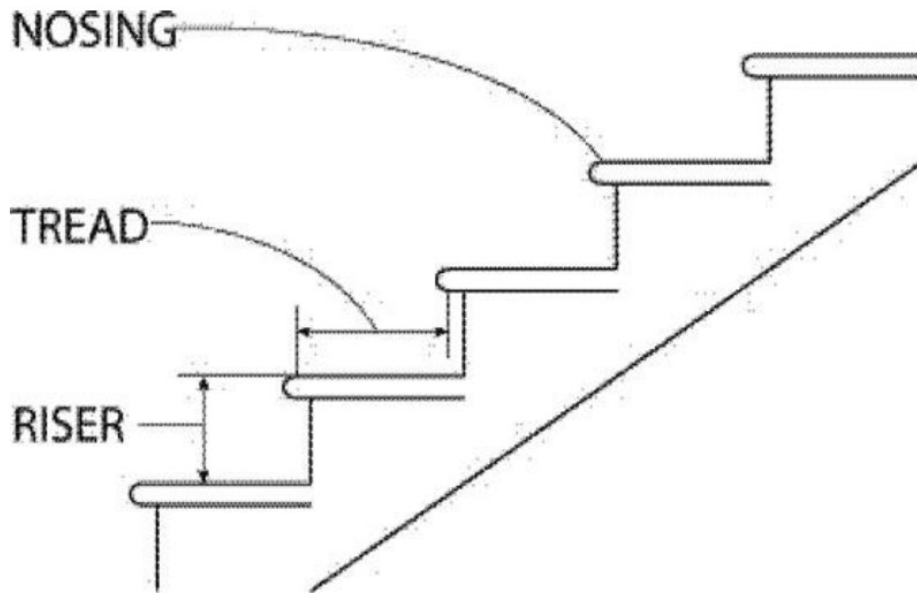

## Door or gate opening onto stairway platform measurements

The swing of a door or gate opening out onto a stairway platform cannot reduce the platform's effective usable depth to:

- a. Less than 20 inches if stair platform installed before October 1, 2020
- b. Less than 22 inches if stair platform installed on or after October 1, 2020

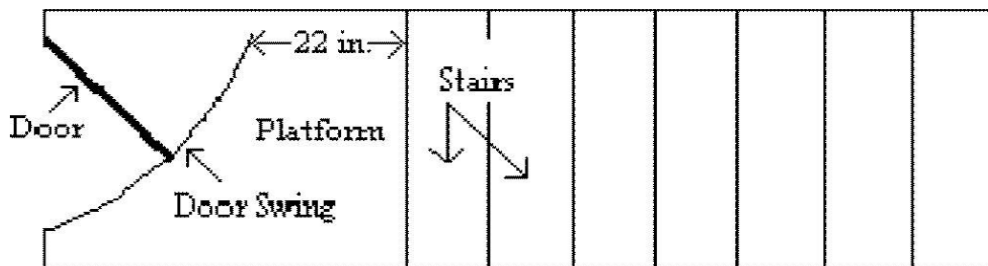

## Appendix E. Roof Access Permit

See next page.

A fillable form Word document is available on the [EH&S website](#).

Enter information electronically in shaded areas, name Word document file, and save to device. Or print document to enter information manually.

## Roof Access Permit

This permit is completed by: (1) Contractor supervisor/manager of contracted employees who will access the roof; with (2) UW Point of Contact (project manager/supervisor/building coordinator). If there are changes to the scope of work, hazards, and/or safeguards identified on an active Roof Access Permit, a new Roof Access Permit must be completed.

| General Information   |   |   |
|---|---|---|
| Person(s) and Company Requesting Permit: <a href="#">Click to enter text</a>  |   |   |
| Building: <a href="#">Click to enter text</a>   |   |   |
| Area of roof to be accessed (be specific – attach sketch/photos of roof and area of intended access): <a href="#">Click to enter text</a> |   |   |
| Task to be performed: <a href="#">Click to enter text</a>   |   |   |
| Date(s) of access:  | Start date: <a href="#">Click to enter date</a>                           | Close date: <a href="#">Click to enter date</a>   |
| Date of Pre-task planning meeting of Contractor and UW Point of Contact : <a href="#">Click to enter date</a>                             |   |   |
| Identification of Potential Hazards (check all that apply)  |   |   |
| <input type="checkbox"/> Low slope roof (4:12 or less)  | <input type="checkbox"/> Rooftop obstructions greater than 30 inches high | <input type="checkbox"/> Different levels of roof requiring access                      |
| <input type="checkbox"/> Steep slope roof (greater than 4:12)   | <input type="checkbox"/> RF radiation (cell phone tower)                  | <input type="checkbox"/> Elevated mechanical equipment within 10 feet of perimeter edge |
| <input type="checkbox"/> Parapet wall less than 42 inches high  | <input type="checkbox"/> Perimeter leading edge work                      | <input type="checkbox"/> Slippery when wet  |
| <input type="checkbox"/> Skylights  | <input type="checkbox"/> Roof openings (ladder openings, holes, etc.)     | <input type="checkbox"/> Other: <a href="#">Click to enter text</a>                     |
| <input type="checkbox"/> Controlled access zone   | <input type="checkbox"/> Roof hatches within 10 ft. of perimeter edge     | <input type="checkbox"/> Other: <a href="#">Click to enter text</a>                     |
| <input type="checkbox"/> Roof assessment/evaluation issues  | <input type="checkbox"/> Uncontrolled access zone                         | <input type="checkbox"/> Other: <a href="#">Click to enter text</a>                     |
| Safety Preparations (check all that apply)  |   |   |
|   | Describe Safeguards and Actions Required                                  |   |
| <input type="checkbox"/> Minimum of two persons performing work (required)  | <a href="#">Click to enter text</a>                                       |   |
| <input type="checkbox"/> Radio communication to/from ground established (required)  | <a href="#">Click to enter text</a>                                       |   |
| <input type="checkbox"/> Lighting provided for night work   | <a href="#">Click to enter text</a>                                       |   |
| <input type="checkbox"/> Weather conditions safe  | <a href="#">Click to enter text</a>                                       |   |
| <input type="checkbox"/> Falling object protection provided   | <a href="#">Click to enter text</a>                                       |   |
| <input type="checkbox"/> Fall protection/work plan (required - must be attached)  | <a href="#">Click to enter text</a>                                       |   |
| <input type="checkbox"/> Skylights, roof openings and holes covered or guarded with covers/guardrails meeting regulated strength          | <a href="#">Click to enter text</a>                                       |   |
| <input type="checkbox"/> RF non-ionizing radiation hazard map   | <a href="#">Click to enter text</a>                                       |   |
| <input type="checkbox"/> Safe work practices for mechanical equipment use reviewed  | <a href="#">Click to enter text</a>                                       |   |
| <input type="checkbox"/> Hot work permit  | <a href="#">Click to enter text</a>                                       |   |
| <input type="checkbox"/> Evaluate roof loading – added support required?  | <a href="#">Click to enter text</a>                                       |   |
| <input type="checkbox"/> Other: <a href="#">Click to enter text</a>   | <a href="#">Click to enter text</a>                                       |   |
| <input type="checkbox"/> Other: <a href="#">Click to enter text</a>   | <a href="#">Click to enter text</a>                                       |   |





| Review/Access   |                                     |                                     |                                     |
|---|-------------------------------------|-------------------------------------|-------------------------------------|
| <b>Important Note:</b> Permit reviewer(s) cannot be the person(s) accessing the roof. |                                     |                                     |                                     |
|   | Name                                | Signature                           | Date                                |
| UW Point of Contact (project manager/supervisor/building coordinator)                 | <a href="#">Click to enter text</a> |                                     | <a href="#">Click to enter date</a> |
| Contractor supervisor/manager (of contracted employees who will access roof)          | <a href="#">Click to enter text</a> |                                     | <a href="#">Click to enter date</a> |
| Permit Expires:   | Date:                               | <a href="#">Click to enter date</a> | Time:                               |





| Contracted employee(s) trained to work under this permit |           |                                     |
|--|-----------|-------------------------------------|
| Name (print)   | Signature | Date                                |
| <a href="#">Click to enter text</a>                      |           | <a href="#">Click to enter date</a> |
| <a href="#">Click to enter text</a>                      |           | <a href="#">Click to enter date</a> |
| <a href="#">Click to enter text</a>                      |           | <a href="#">Click to enter date</a> |
| <a href="#">Click to enter text</a>                      |           | <a href="#">Click to enter date</a> |
| <a href="#">Click to enter text</a>                      |           | <a href="#">Click to enter date</a> |
| <a href="#">Click to enter text</a>                      |           | <a href="#">Click to enter date</a> |

**Post this permit at the entrance to the roof.**





## Appendix F. Personal fall protection equipment

All equipment must be ANSI approved. All equipment must be inspected before each use by an Authorized Person, inspected annually by a Competent Person, and taken out of service if it fails inspection or is involved in a fall.

| PPE                            | Specific Type   | Characteristics   | Applications   |
|--------------------------------|---|---|--|
| <b>Full body harness</b>       |    | Provides protection from injury while falling from heights  | Working at heights (greater than 4 feet)   |
| <b>Locking carabiner</b>       |   | Connecting components of a fall protection system   | Working at heights (greater than 4 feet)   |
| <b>Snap-hook</b>               |  |   |  |
| <b>Shock absorbing lanyard</b> |  | Provides connection from harness to anchor point with ability to lessen fall force factor, working length of 6 feet | Working at heights (greater than 18.5 feet of fall clearance) for fall arrest situations |

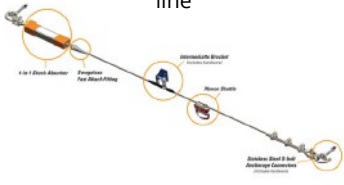
|   |  |   |  |
|---|--|---|--|
| <p><b>Shock absorbing lanyard (cont.)</b></p>   |  <p>Double tie-off Y-lanyard</p>  | <p>Y-lanyard used to transfer between anchors</p>   |  |
| <p><b>Self-retracting lifeline w/swivel</b></p> |   | <p>Provides connection from harness to anchor, shorter activation distance reduces fall force factor</p>      | <p>Working at heights for fall arrest situations where greater worker mobility is needed</p> |
| <p><b>Anchor</b></p>                            | <p>Temporary I-beam trolley</p>  <p>Temporary anchor strap on I-beam</p>  <p>Permanent roof anchor</p>  | <p>Primary point of attachment for a fall arrest protection system, minimum 5,000 pound breaking strength</p> | <p>Working at heights (greater than 4 feet)</p>  |



|  |  |   |  |
|--|--|---|--|
|  | <p>Horizontal life line</p>  <p>Rope grab</p>  | <p>Anchor variations include horizontal and vertical life lines. Rope grab moves along life line in open position, grabs line in event of a fall.</p> |  |
| <p><b>Positioning lanyard</b></p>            |   | <p>Clips to both sides of waist D-rings so the center clip can attach to a secure anchor.</p>   | <p>A person can be positioned so they can work with both hands while secured to an anchor.</p> |
| <p><b>Suspension trauma relief strap</b></p> |    | <p>Strap is a webbing loop that unfurls from the harness.</p>   | <p>Provides a means for the person suspended after a fall to avoid suspension trauma.</p>      |

[Back to Top](#)

## Appendix G. Inspecting fall protection equipment guides

**Q: How often do I have to inspect my harness? What do I look for inspecting a harness?**

**A:** Inspect the harness every time you have to wear it. To inspect your harness, perform the following procedures:



### 1) Webbing

Grasp the webbing with your hands 6 inches (152mm) to 8 inches (203mm) apart. Bend the webbing in an inverted “U” as shown. The surface tension resulting makes damaged fibers or cuts easier to detect. Follow this procedure the entire length of the webbing, inspecting both sides of each strap. Look for frayed edges, broken fibers, pulled stitches, cuts, burns and chemical damage.



### 2) D-Rings/Back Pads

Check D-rings for distortion, cracks, breaks, and rough or sharp edges. The D-ring should pivot freely. Inspect for any unusual wear, frayed or cut fibers, or broken stitching of the D-ring attachments. Pads should also be inspected for cracks, excessive wear, or other signs of damage.



### 3) Buckles

Inspect for any unusual wear, frayed or cut fibers, or broken stitching of the buckle attachments.



### 4) Tongue Buckles/Grommets

Buckle tongues should be free of distortion in shape and motion. They should overlap the buckle frame and move freely back and forth in their socket. Roller should turn freely on frame. Check for distortion or sharp edges. Inspect for loose, distorted or broken grommets. Webbing should not have additional punched holes.



### 5) Friction and Mating Buckles

Inspect the buckle for distortion. The outer bars and center bars must be straight. Pay special attention to corners and attachment points at the center bar.



### 6) Quick-Connect Buckles

Inspect the buckle for distortion. The outer bars and center bars must be straight. Make sure dual-tab release mechanism is free of debris and engages properly.



### 7) Harness Fall Arrest Indicators

Inspect fall arrest indicators (located on the back D-ring pad) for signs of activation. Remove from service if broken or stretched between any of the four (4) pairs of arrows.

**Q: What do I look for when inspecting a lanyard?**

**A:** When inspecting lanyards, begin at one end and work to the opposite end, slowly rotating the lanyard so that the entire circumference is checked. Additionally, follow the procedures below.



**1) Hardware**

**A) Snaps:** Inspect closely for hook and eye distortions, cracks, corrosion, or pitted surfaces. The keeper (latch) should seat into the nose without binding and should not be distorted or obstructed. The keeper spring should exert sufficient force to firmly close the keeper. Keeper locks must prevent the keeper from opening when the keeper closes.



**B) Thimbles:** The thimble must be firmly seated in the eye of the splice, and the splice should have no loose or cut strands. The edges of the thimble must be free of sharp edges, distortion, or cracks.



**2) Wire Rope Lanyard**

Always wear gloves when inspecting a wire rope lanyard; broken strands can cause injury. While rotating the wire rope lanyard, watch for cuts, frayed areas or unusual wearing patterns on the wire. Broken strands will separate from the body of the lanyard.



**3) Web Lanyard**

While bending webbing over a pipe or mandrel, observe each side of the webbed lanyard. This will reveal any cuts, snags or breaks. Swelling, discoloration, cracks and charring are obvious signs of chemical or heat damage. Observe closely for any breaks in stitching. Inspect lanyard warning flag for signs of activation. Titan tubular lanyards must be measured to determine activation.



**4) Rope Lanyard**

Rotate the rope lanyard while inspecting from end-to-end for any fuzzy, worn, broken or cut fibers. Weakened areas from extreme loads will appear as a noticeable change in original diameter. The rope diameter should be uniform throughout, following a short break-in period.



**5) Shock Absorber Pack**

The outer portion of the pack should be examined for burn holes and tears. Stitching on areas where the pack is sewn to D-rings, belts or lanyards should be examined for loose strands, rips, deterioration or other signs of activation.

## Self-retracting lifeline inspection



### (1) Housing

Before every use, inspect the unit's housing for loose fasteners and bent, cracked, distorted, worn, malfunctioning, or damaged parts.



### (2) Lifeline

Test the lifeline retraction and tension by pulling out several feet of the lifeline and allow it to retract back into the unit. Always maintain a light tension on the lifeline as it retracts. The lifeline should pull out freely and retract all the way back into the unit. Do not use the unit if the lifeline does not retract. The lifeline must be checked regularly for signs of damage. Inspect for cuts, burns, corrosion, kinks, frays or worn areas. Inspect any sewing (web lifelines) for loose, broken, or damaged stitching.



### (3) Braking Mechanism

The braking mechanism must be tested by grasping the lifeline above the impact indicator and applying a sharp steady pull downward, which will engage the brakes. There should be no slippage of the lifeline while the brakes are engaged; once tension is released, the brakes will disengage and the unit will return to the retractable mode. Do not use the unit if the brakes do not engage.

### (4) Hardware

Check the hardware as directed above. The snap hook load indicator is located in the swivel of the snap hook. The swivel eye will elongate and expose a red area when subjected to fall arresting forces. Do not use the unit if the load impact indicator has been activated.

[Back to Top](#)

## Log of revisions to Fall Protection Program Manual

| Date             | Revisions  |
|------------------|--|
| November 1, 2022 | <p>Revised the following sections to reflect revised unified fall protection rules following an OSHA review:</p> <ul style="list-style-type: none"> <li>• Definitions               <ul style="list-style-type: none"> <li>○ New: infrequent and temporary</li> <li>○ Revised: Safety Watch</li> </ul> </li> <li>• Trigger heights for construction work (roofing and leading edge) changed from 10 feet to six feet</li> <li>• Safety Watch allowed on low slope roofs, for activities other than construction work when performed both infrequently and temporary and not within six feet from edge. Using Alternate Fall Protection on Roof information (focus sheet) to include revised regulatory requirements.</li> </ul> <p>Updated links in Theater Fall protection section</p>  |
| February 2021    | <p>The following sections were updated to reflect new WAC regulations for Unified Fall Protection rule and other updates:</p> <ul style="list-style-type: none"> <li>• Introduction</li> <li>• Scope</li> <li>• Fall Protection Trigger Heights table</li> <li>• Fall Protection Requirements</li> <li>• Walking-Working Surfaces</li> <li>• Mobile Elevated Working Platforms</li> <li>• Ladders</li> <li>• Training</li> </ul> <p>The following forms and guidance documents were updated:</p> <ul style="list-style-type: none"> <li>• Fall Protection Work Plan</li> <li>• Walking-working surfaces inspection form</li> <li>• Portable Ladder inspection form</li> <li>• Using Alternative Fall Protection on Roofs guidance document</li> <li>• Ladder Safety focus sheet</li> </ul> <p>An appendix was added on new regulations for stairway railings and stairway railing systems.</p> |
| May 2019         | <p>Roof Activities section updated to include requirements for contractor access to roofs and use of the Roof Access Permit form. Appendix added with new Roof Access Permit form.</p>   |

|              |                      |
|--------------|----------------------|
| October 2018 | Original publication |
|--------------|----------------------|

[Back to Top](#)